

THAVZALL

Tamarack Industries

HEATZONE™



TCH250

Operators Manual



As a new customer of Thawzall we would like to welcome you! We are looking forward to providing you with technical support for your Thawzall unit. Whatever you need we are here to help.

Ways to contact us for support

By Phone : 1-888-757-3545

The main Technical support phone line is staffed monday-friday 7:00 AM to 3:30 PM excluding holidays.

After hours support

Calls received outside of regular hours are directed to the On-call technician. After hours support is reserved for issues that cannot wait until the next business day for resolution. If no answer please leave a message and we will get back to you as soon as possible.

By Email : support@tamarack-ind.com

Feel free to email us at any time with technical questions or parts inquiries. Please include the year make and model of your unit if you have a specific question about your machine so we can better help you. If it is an emergency please call 1-888-757-3545

For more information please visit our website

www.thawzall.com

Operators Manual

For model:

TCH 250

Please record the following information from your new Thawzall for future reference. This information is required for all warranty claims.

Purchase date: _____/_____/_____

Generator make: _____

Machine model: _____

Generator KW: _____

Machine serial number: _____

Generator Serial #: _____

Serial number located on trailer tongue

Manufactured by Thawzall, LLC

A DIVISION OF TAMARACK INDUSTRIES

2736 Lakota Lane Unit B

Alexandria, MN 56308

Phone 320.759.1588

Fax: 320.759.1583

Tech Support 888.757.3545

Website: www.Thawzall.com

E-Mail: support@tamarack-ind.com



WARNING



CALIFORNIA - Proposition 65 Warning

Engine exhaust and some of its constituents and some dust created by power sanding, sawing, grinding, drilling and other construction activities contains chemicals known to the State of California to cause cancer, birth defects and other reproductive harm.

Some examples of these chemicals are:-

- Lead from lead-based paints
- Crystalline silica from bricks
- Cement and other masonry products
- Arsenic and chromium from chemically treated lumber

Your risk from these exposures varies, depending on how often you do this type of work. To reduce your exposure to these chemicals:

ALWAYS work in a well ventilated area, and work with approved safety equipment, such as dust masks that are specially designed to filter out microscopic particles.

INTRODUCTION

Congratulations on your choice of a Tamarack Industries Thawzall TCH250 to complement your construction operation. This equipment has been designed and manufactured to meet the needs of the buyer for the efficient heating of construction sites.

Safe, efficient and trouble free operation of your TCH250 requires that you and anyone else who will be operating or maintaining the Heater, read and understand the Safety, Operation, Maintenance and Trouble Shooting information contained in the Operator's Manual.



This manual is applicable to the TCH250 built by Tamarack Industries. Use the Table of Contents as a guide when searching for specific information.

Keep this manual handy for frequent reference and to pass on to new operators or owners.

Table of contents

Title	Pages
Ways to contact Us	1
Unit Information	2
Warning	3
Introduction	4
Safety	6-11
Warranty	12-13
How It Works	14
Controls	15-19
Operation	20-28
Ground Thaw Set Up	29-33
Troubleshooting	34-37
Alarms	38-40
Maintenance	41-48
Specifications	49
MSDS	50-59
Schematics	60-65

SAFETY

SAFETY ALERT SYMBOL

This Safety Alert symbol means
ATTENTION! BECOME ALERT!
YOUR SAFETY IS INVOLVED!



The Safety Alert symbol identifies important safety messages on the Tamarack Heat King and in the manual. When you see this symbol, be alert to the possibility of personal injury or death. Follow the instructions in the safety message.

Why is SAFETY important to you?

3 Big Reasons

Accidents Disable and Kill
Accidents Cost
Accidents Can Be Avoided

SIGNAL WORDS:

Note the use of the signal words **DANGER**, **WARNING** and **CAUTION** with the safety messages. The appropriate signal word for each message has been selected using the following guide-lines:

DANGER - Indicates an imminently hazardous situation that, if not avoided, will result in death or serious injury. This signal word is to be limited to the most extreme situations, typically for machine components that, for functional purposes, cannot be guarded.

WARNING - Indicates a potentially hazardous situation that, if not avoided, could result in death or serious injury, and includes hazards that are exposed when guards are removed. It may also be used to alert against unsafe practices.

CAUTION - Indicates a potentially hazardous situation that, if not avoided, may result in minor or moderate injury. It may also be used to alert against unsafe practices.

Safety, Installation & Operation

SAFETY

YOU are responsible for the **SAFE** operation and maintenance of your Tamarack Industries Heat King. **YOU** must ensure that you and anyone else who is going to operate, maintain or work around the Heat King be familiar with the operating and maintenance procedures and related **SAFETY** information contained in this manual. This manual will take you step-by-step through your working day and alerts you to all good safety practices that should be adhered to while operating the Heater.

Remember, **YOU** are the key to safety. Good safety practices not only protect you but also the people around you. Make these practices a working part of your safety program. Be certain that **EVERYONE** operating this equipment is familiar with the recommended operating and maintenance procedures and follows all the safety precautions. Most accidents can be prevented. Do not risk injury or death by ignoring good safety practices.

- Heater owners must give operating instructions to operators or employees before allowing them to operate the machine, and at least annually thereafter.
- The most important safety device on this equipment is a SAFE operator. It is the operator's responsibility to read and understand ALL Safety and Operating instructions in the manual and to follow these. Most accidents can be avoided.
- A person who has not read and understood all operating and safety instructions is not qualified to operate the machine. An untrained operator exposes himself and bystanders to possible serious injury or death.
- Do not modify the equipment in any way. Unauthorized modification may impair the function and/or safety and could affect the life of the equipment.
- Think SAFETY! Work SAFELY!

GENERAL SAFETY

1. Read and understand the Operator's manual and all safety signs before operating, maintaining, adjusting, servicing or cleaning the Heater.

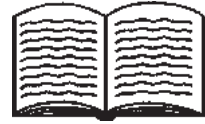

2. Only trained competent persons shall operate the Heater. An untrained operator is not qualified to operate the machine.

3. Have a first-aid kit available for use, should the need arise and know how to use it.



4. Do not allow riders.

5. Have a fire extinguisher available for use should the need arise and know how to use it.



6. Wear appropriate protective gear. This list includes, but is not limited to:

- A hard hat
- Protective boots with slip resistant soles
- Protective goggles
- Heavy gloves
- Hearing protection



7. Place all controls in their OFF position, disconnect power cords and wait for all moving parts to stop before servicing, adjusting or maintaining

8. Wear appropriate hearing protection when operating for long periods of time.



9. Wear protective gloves



10. Ventilation ~ Never operate in a poorly ventilated or enclosed area. Avoid prolonged breathing of exhaust gases.



11. Hot surface ~ Avoid contact with hot exhaust and glycol system. Allow to cool before performing repairs or service.



12. Electrocution Hazard ~ Always use proper size grounded extension cord. Inspect all extension cords for cuts, frayed wires and broken connectors. Do not use cords if not in good condition.



13. Fire Hazard ~ Do not operate machine in the vicinity of open flames, sparks or while smoking.



14. Explosion Hazard ~ Battery
Take care when handling battery (if installed)



ELECTRICAL SAFETY

1. Place all controls in their OFF position, disconnect power cords and wait for all moving parts to stop before servicing, adjusting or maintaining.
2. Place all controls in their OFF position before plugging in power cords.
3. Keep all electrical components in good repair before starting.
4. Do not lay power lines or connectors in water or on a wet surface. Dry connectors and raise power lines out of the water before and during operation.
5. Do not operate machine if there are electrical malfunctions. Correct problem before resuming work.

TIRE SAFETY

1. Failure to follow proper procedures when mounting a tire on a wheel or rim can produce an explosion which may result in serious injury or death.
2. Do not attempt to mount a tire unless you have the proper equipment and experience to do the job.
3. Have a qualified tire dealer or repair service perform required tire maintenance.
4. Torque wheel nuts to 120 ft-lbs

STORAGE SAFETY

1. Store unit in an area away from human activity.
2. Do not permit children to play on or around the stored Heater.



FUEL SAFETY



Danger: To avoid possible injury, fire, or explosion, please read and follow these instructions.

1. Handle fuel with care. It is highly flammable.
2. Allow burners to cool for 5 minutes before refueling. Clean up spilled fuel before restarting engine.
3. Do not refuel the machine while smoking or when near open flame or sparks.
4. Always use an approved fuel container.
5. Fill fuel tank outdoors.
6. Prevent fires by keeping machine clean of accumulated trash, grease and debris.

MAINTENANCE SAFETY

1. Review the Operator's Manual and all safety items before working with, maintaining or operating the Heater.
2. Place all controls in their OFF position, disconnect power cords and wait for all moving parts to stop before servicing, adjusting or maintaining.
3. Follow good shop practices:

- Keep service area clean and dry.
- Be sure electrical outlets and tools are properly grounded.
- Use adequate light for the job at hand.



4. Keep hands, feet, clothing and hair away from all moving and/or rotating parts.
5. Always wear heavy gloves to prevent burns when handling hot components. Wait until burners, coils and glycol system components have cooled before working on them.
6. Do not attempt any adjustment or maintenance to any system of the Heater unless the power wires are disconnected from the battery.
7. Make sure that all guards, shields and hoods are properly installed and secured before operating the Heater.
8. Securely support the machine using blocks or safety stands before working beneath it or changing tires.
9. Store and transfer diesel fuel, solvents, cleaners or any flammable liquids only in safety standard approved containers.



OPERATING SAFETY

1. Read and understand the Operator's Manual and all safety signs before operating, servicing, maintaining or adjusting the Heater.
2. Place all controls in their OFF position, disconnect power cords and wait for all moving parts to stop before servicing, adjusting or maintaining.
3. Do not allow riders in or on machine during transport.
4. Clear the area of bystanders, especially small children, before starting and operating.
5. Keep the working area clean and free of debris to prevent slipping or tripping. Clean up fuel spills immediately if they occur.
6. Slow down. Use care when working around unit - the steps, frame or floor may be wet and/or slippery.
7. Do not allow personnel that are taking drugs, alcohol or any medications that impair the senses or when excessively tired or stressed to operate the Heater.
8. Do not operate unit in a poorly ventilated or enclosed area to prevent asphyxiation when the heaters are operating.
9. Do not smoke when connecting fuel source or when working around machine.
10. Always wear heavy gloves when working on the machine to prevent burns when touching hot components.
11. Use the foot pedal switch to engage the hose reel take up or extend function and guide the hose by hand.
12. Keep all electrical lines and components in good working order. Do not operate in wet conditions or when standing in water. Damp or wet conditions can cause shocks or trip the breakers.
13. Keep all components in good condition.
14. Do Not plug or block access doors or vents. Keep 1 foot of clearance around unit.
15. Review safety instructions with operators annually.

SAFE TRANSPORTATION AND STORAGE



TRANSPORTING SAFETY

1. Attach to towing vehicle and secure with a mechanical retainer. Cross the safety chains under the hitch and anchor to truck frame.
2. Connect the brake anchor cable to the truck frame to activate the trailer brakes if the trailer unexpectedly unhooks. Provide sufficient slack for turning.
3. Check that all lights and reflectors required by the DOT are clean and functioning.
4. Do not exceed 55 mph under ideal conditions.
5. Do not allow riders on machine.
6. Do not drink and drive.

When transporting the machine, review and follow these instructions:

1. Be sure all bystanders are clear of the machine.
2. Back the truck up to the hitch and lower hitch over the ball.
3. Secure with a mechanical retainer.
4. Cross the safety chains under the hitch and attach to truck frame.
5. Attach the brake line to the truck frame. Be sure to leave sufficient slack for turning.
6. Connect electrical harness to truck plug-in.
7. Raise and secure the hitch jack.
8. Reverse the Heat King set-up procedure t
9. Check and be sure that all lights are working.
10. Do not allow riders on machine.
11. Never exceed a safe travel speed.
12. Do not drink and drive.
13. Check with local highway authorities on the specific requirements for transporting fuel oil through their jurisdiction. Always comply with the requirements before transporting.



WARNING

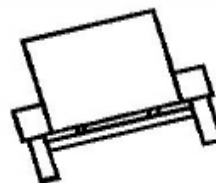

TRAILER TOWING CAN BE HAZARDOUS

- * DO NOT exceed 55 mph under ideal conditions
- * Reduce speed under adverse weather, road or terrain conditions
- * Avoid sudden lane changes, U-turns etc.
- * Sudden maneuvers may cause tipping, rollover, jackknifing or sliding of the trailer and without warning loss of control of the towing vehicle may result.
- * Allow for increased braking distance due to weight of trailer
- * Read the Operator's Manual before towing.

**TAMARACK INDUSTRIES
THAWZALL**

WARRANTY REGISTRATION FORM & INSPECTION REPORT

WARRANTY REGISTRATION (please print)

This form must be filled out by the dealer and signed by both the dealer and the customer at the time of delivery.

Customer's Name _____	Distributor Name _____
Address _____	Address _____
City, State, Code _____	City, State, Code _____
Phone Number (____) _____	Check One:
Contact Name _____	Private <input type="checkbox"/>
THAWZALL Model _____	Contractor <input type="checkbox"/>
Serial Number _____	Other _____
Delivery Date _____	

DISTRIBUTOR INSPECTION REPORT

- ___ Tire Pressure Checked
- ___ Wheel Bolts Torqued
- ___ Brakes Work
- ___ Check Fluid Levels (Fuel and Glycol)
- ___ Lubricate Machine
- ___ Check That All Controls Function
- ___

SAFETY

- ___ Emergency Stop Switch Works
- ___ All Decals Installed and Legible
- ___ Lights and Reflectors Installed, Clean and Working
- ___ Review Operating And Safety Instructions

I have thoroughly instructed the buyer on the above described equipment which review included the Operator's Manual content, equipment care, adjustments, safe operation and applicable warranty policy.

Date _____ Dealer's Rep. Signature _____

The above equipment and Operator's Manual have been received by me and I have been thoroughly instructed as to care, adjustments, safe operation and applicable warranty policy.

Date _____ Owner's Signature _____

Tamarack Industries CONDITIONS OF SALES & LIMITED WARRANTY

All sales made by Tamarack Industries, here after referred to as Tamarack, a Division of ELJO Industries Inc. are subject to these conditions unless otherwise agreed in writing with a duly authorized officer of Tamarack. In all cases of conflict between these conditions and the requirements of the purchase order, these conditions shall prevail.

(1) SALES POLICY: Nothing herein shall be construed as abridging the right of Tamarack to sell directly or indirectly to: (a) Federal, State or Provincial Governments or Agencies thereof, or to Agencies employing Federal, State or Provincial Government aid; (b) Purchasers who buy Tamarack's products for sale as integral or assembled parts of their products; (c) Firms operating on a national scale; (d) Any other class of purchaser to whom Tamarack may from time to time, elect to sell.

(2) PRICES: All prices are F.O.B. our warehouses, freight allowance as specified on Distributor Net Price Lists. The suggested list prices and discounts schedules are established by Tamarack and are intended to act as a guide for our distributors. Unless otherwise stated in writing, prices are subject to change without notice and will be applied as in effect at time of shipment.

(3) TERMS: Unless otherwise agreed upon in writing by an officer of Tamarack, all invoices become due and payable net 30 days following the date in invoice. Interest at the maximum legal rate will be charged on all overdue accounts. Minimum net charge per invoice is \$75.00

(4) CANCELLATION AND CHANGES: No orders or sales may be cancelled or changed without the consent of Tamarack. At Tamarack's option cancelled/changed orders are subject to payment of cancellation charges equal to all costs incurred by Tamarack up to the date of cancellation/change.

(5) DELAYED DELIVERIES: Tamarack shall not be liable for any delay of merchandise for any cause whatsoever.

(6) CLAIMS: All goods shall be deemed delivered to purchaser at the time they are placed in the hands of carrier and consigned to purchaser: loss, damage or destruction of any said merchandise is assumed by purchaser. No claims may be made for shortages unless made in writing within ten days from receipt of merchandise.

(7) RETURN OF GOODS: Written permission from Tamarack must be obtained before returning any merchandise. All transportation charges must be borne by the purchaser. Credit for returned goods will be based on the original price paid, less 20%. Special parts or custom-built items cannot be returned for credit.

(8) LIMITATION OF LIABILITY: Tamarack's liability on any claim of any kind, including negligence, for any loss or damage arising out of, connected with, or resulting

from contract, or the performance or breach thereof, or the design, manufacture, sale, delivery, resale, installation, technical direction of installation, inspection, repair, operation or use of any equipment covered by or furnished under contract shall in no case exceed the price paid by the purchaser for the equipment. Tamarack also disclaims all purchaser for the equipment. Tamarack also disclaims all liability, whether in contract, tort, warranty, or otherwise, to any party other than purchaser.

(9) All Price Lists, Catalogues and other material shall remain the property of Tamarack and are subject to return on demand. The Suggested List Prices are established by Tamarack and are intended to act as a guide. All shipping weights shown are approximate.

LIMITED TAMARACK WARRANTY

For two years from date of purchase, Tamarack will replace or repair for the original purchaser, free of charge, any part or parts, found upon examination by any Tamarack Authorized Service Depot or by the Tamarack factory, to be defective in material or workmanship or both. Equipment and accessories not manufactured by Tamarack are warranted only to the extent of the original manufacturer's warranty. All transportation charges on parts submitted for replacement or repair under this warranty must be borne by the purchaser. For warranty service contact your nearest Tamarack Authorized Service Depot.

THERE IS NO OTHER EXPRESS WARRANTY, IMPLIED WARRANTIES, INCLUDING THOSE OF MERCHANTABILITY AND FITNESS FOR A PARTICULAR PURPOSE ARE LIMITED TO ONE YEAR FROM PURCHASE AND TO THE EXTENT PERMITTED BY LAW. LIABILITY FOR CONSEQUENTIAL DAMAGES UNDER ANY AND ALL WARRANTIES ARE EXCLUDED TO THE EXTENT EXCLUSION IS PERMITTED BY LAW. (THIS WARRANTY IS AN ADDITION TO ANY STATUTORY WARRANTY.)

WARRANTY VOID IF NOT REGISTERED

P.O. Box 234, Station "L"
Winnipeg, Manitoba
Canada R3H 0Z5

How It Works

TCH 250 – DIESEL

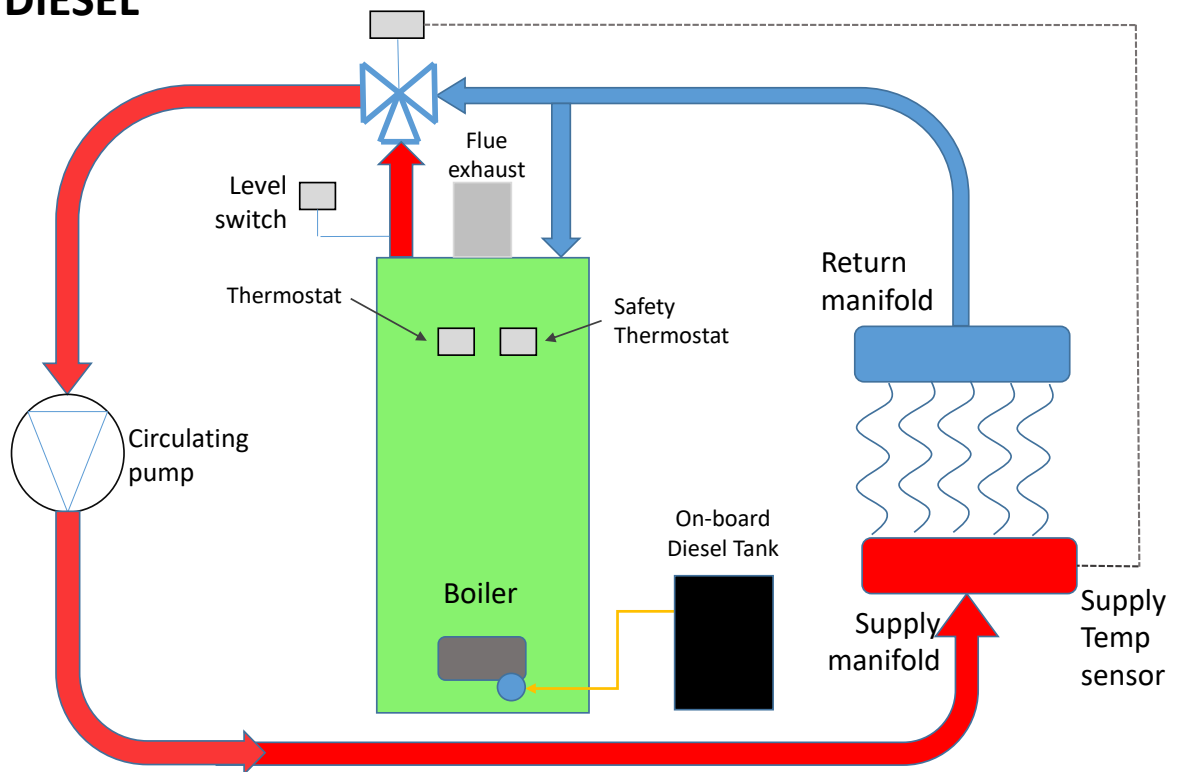

The Thawzall TCH250 is designed to heat a propylene glycol water solution which is then used for ground thawing, concrete curing or space heating. The glycol solution is pumped into the onboard boiler by use of a 1/2hp centrifugal pump, where it is heated and sent out to a distribution manifold for use in the field. This solution is returned from the field into the return manifold and back into the boiler for reheating. An electronically controlled three way valve adjusts the amount of return coolant being directed into the boiler depending on the set temperature requested at the controller. (Operator selected)

The TCH250 is a closed loop system where the glycol/water solution is always stored within the boiler and the field hoses.

A reservoir tank which contains about 12 gallons of the glycol/water solution is also found on board. The solution in this tank can be used to pressurize the closed loop system in the event of pressure loss. A pressure loss can occur from a leak in the system or if the system contained air and it was evacuated through the use of the auto bleeders. This pressurization is accomplished through the use of a pump found inline to the reservoir.

The control panel is located at the right rear side of the unit. All operations are controlled from here including selection of input power preference as well as burner and reel control. The operator can set the required temperature via the HMI (Human Machine Interface). The HMI will also display all the return temperature being read at the manifold so all 5 zone temperatures can be monitored.

Safeties

The unit has a PRV valve which will release excess pressure back into the reservoir in the event of over pressurization. Also found on the top of the water jacket on the boiler is a low glycol shutdown safety. This safety will shut down the boiler in the case of low glycol in the system or excess air in the system. The TCH250 comes with a shutdown thermostat located directly on the boiler in the event of an over temperature condition within the boiler

Controls



Main Status Screen

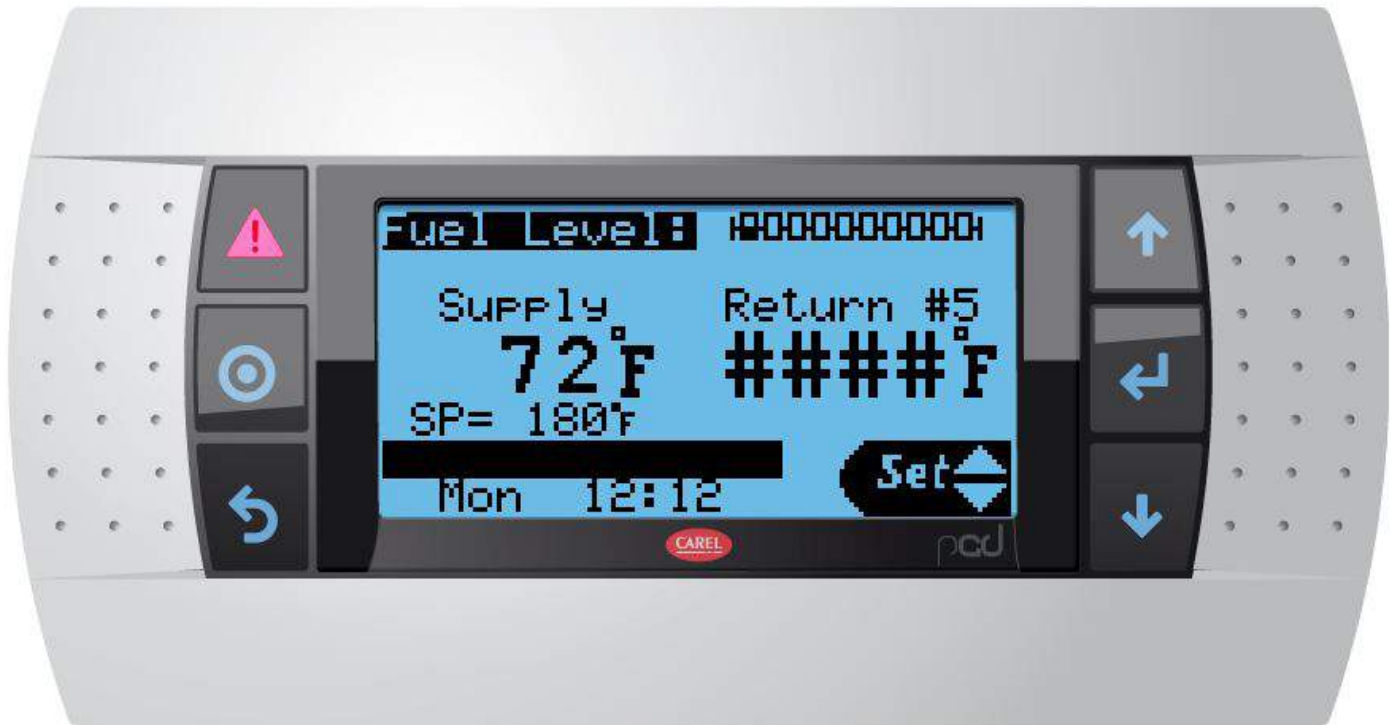

Fuel Level - Current reading of the fuel level sender located in the fuel tank

Supply Temperature- Current reading of the temperature sensor located in the supply line feeding the manifold.

Return Temperature- Current reading of the temperature sensors located in each of the return ports on the manifold. The display will automatically cycle through the temperature readings from each port.

Day/Time- Display of real time date and time.

User Menu- This is a menu which provides quick access to settings and information about the unit. To navigate the user menu use the up/down keys to change the menu items and press the enter key to select a menu item.



Navigating the controller



[Alarm] Key - Pressing this key will display any active alarms and provide read access to historical alarm data. When the key is flashing red, an active unacknowledged alarm is present. Solid red indicates an active acknowledged alarm.



[Program] Key - This key provides access to the various advanced settings of the HA controller. A login password is required to make changes in this area.



[Escape] Key - This key will take the operator back one screen. In any event it can be pressed repeatedly to return to the main start-up screen.



[Up] Key - The up key is used to change menu selections and adjust values within the various screens.



[Enter] Key - The enter key is used to select menu items, save values, and move the cursor between fields on the screen.



[Down] Key - The Down key is used to change menu selections and adjust values within the various screens.

Settings Screen

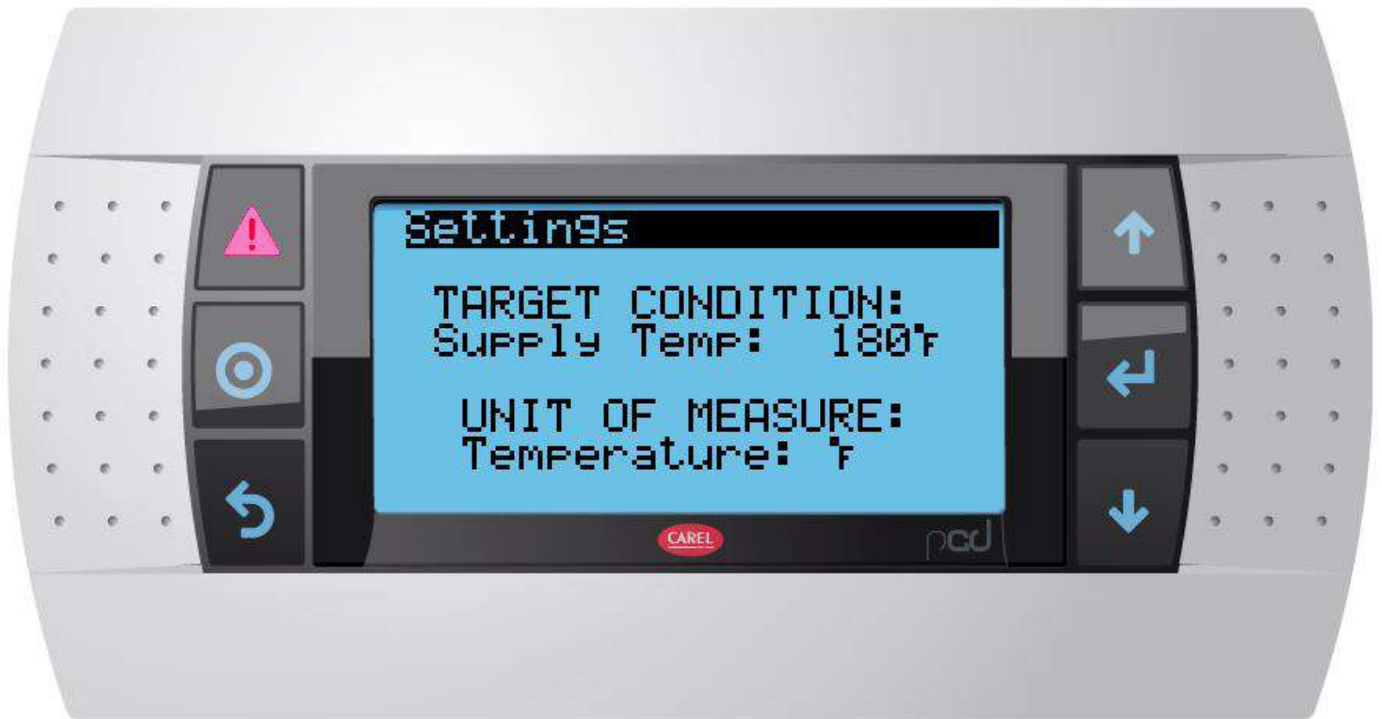

Target Condition- Use the enter key to move the cursor to this field and use the up/down keys to change to the desired target temperature. Once completed press the enter key to save.

Units of Measure- Use the enter key to move the cursor to this field and the up/down keys to toggle between units. Once completed use the enter key to save.

I/O Screen

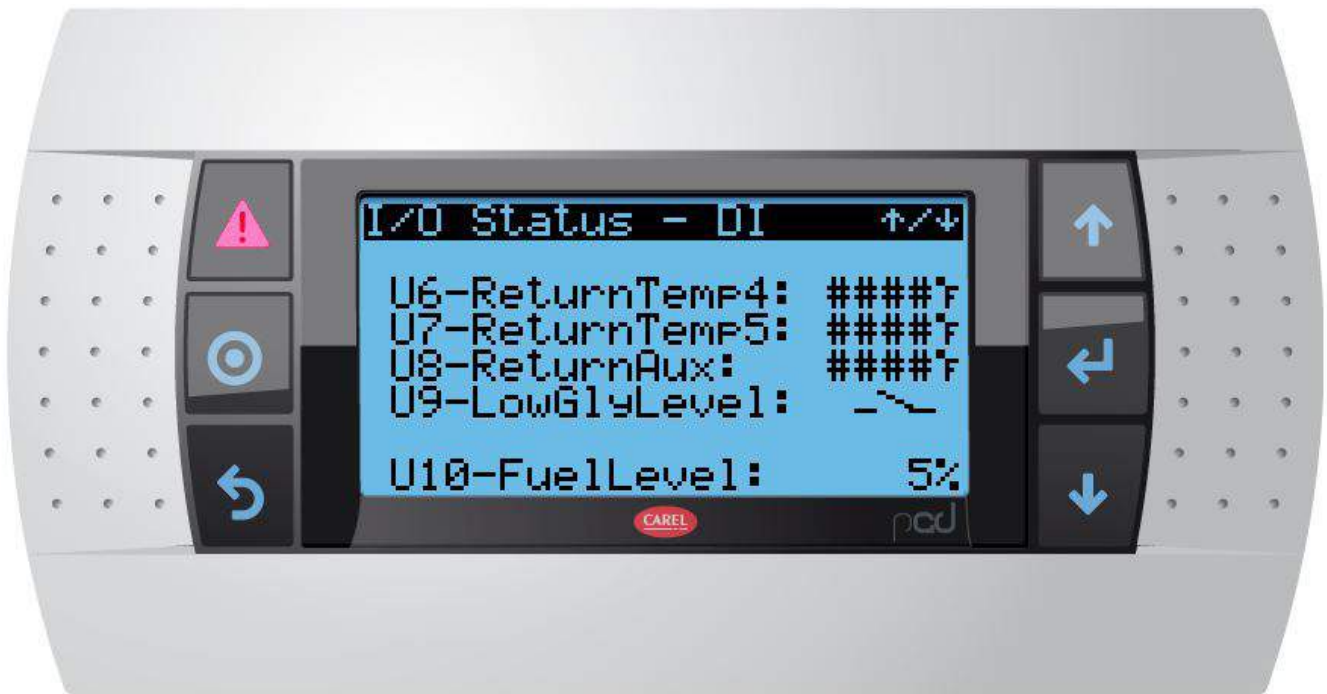

I/O Status- This screen shows the status of the various switches and sensors of the unit. This is strictly for information and no changes can be made on this screen.

Use the up/down arrows to toggle through the different screens.

Pre-Start Checks & Procedures

1. Unit must be leveled for best performance in both directions: front to back, and side to side.
2. Ensure all switches on the control panel – located at the rear of the unit- are in the OFF position.
3. Ensure the unit is powered either by its “on-board” power generator, or by a 115VAC/60Hz x 15A “site power” (shore power).
4. Ensure there is enough Diesel in the fuel tank to operate the unit, and open the tank’s ball valve to feed the unit.
5. Ensure there is between 1/4 to 1/2 level in the glycol reservoir located at the front side of the unit (viewed from the driver’s side service door).

Start-Up Procedure

1. At the control panel, turn the POWER SOURCE switch to GEN or LINE based on how the unit is being powered. (See 3. in the previous section.).
2. Unlock the Hose Reel Locking pin, located to the right side of the hose reel.
3. At the control panel, in the REEL CONTROL module, turn the POWER ON switch to the ON position.

Note: The hose reel can be used in the FREE WHEELING mode OR by engaging the gear box and belt mechanism which requires the use of the foot pedal. Follow instructions at the gear box and belt mechanism, located below the control panel

4. If using FREE WHEELING, turn the belt tension knob counter clockwise to remove belt tension. Manually spin the drum until the first quick connect is located, and start unwinding the hoses, one length at a time.
5. If using the gear box and belt mechanism, at the control panel’s REEL CONTROL module, turn the REEL DIRECTION switch to the OUT position, and using the foot switch, uncoil the hoses as required, one length at a time.
6. As hoses are now on the ground, plug each end of the hose into the same position in each manifold (supply and return), so each section is properly monitored by the control system.
7. Repeat step 6 with as many circuits as required.
8. The unit is now ready to start, so at the HEATER CONTROL module turn the MAIN POWER switch ON and wait for the Home screen to appear on the display. The unit will start automatically.
9. Two settings are accessible to the user at the display:

* Temperature unit: °C or °F (default)

* Set Temperature

To edit the default settings, from the main screen press ↓ until “Set” appears at the bottom right hand corner of the display.

Press return key twice to access to the Temperature unit. Use ↓ to toggle between °F and °C.

Press return key once to move the cursor to the set temperature. Use ↑ or ↓ to increase or decrease the temperature.

Press Esc to return to Main screen.

Recommended Set Points are (contact our customer support for other conditions):

- a. Select 180° F, (or 82° C) for optimum thawing, or
- b. 80° F, (or 26° C) for optimum cold weather concrete curing.

10. If the unit starts without alarms, ensure the "Tridicator" gauge (temp+ pressure) located at the boiler, (driver side) shall display the unit operating pressure between 5 and 10 PSI .
11. If the unit displays a LOW LEVEL alarm, follow the "fill up" instructions located at the boiler when accessing the unit from the driver's side service door, then reset the low level switch (located right above the boiler (driver side)).
12. Inspect the unit for leaks. (tanks, hoses, boiler, and manifolds). Repeat same inspection after one hour (or once the unit is at temperature).

Shut-Down Procedure

1. At the control, HEATER CONTROL module turn the MAIN POWER switch to the OFF position.
2. The unit will automatically start a "cool down" run taking the unit to 130°F (54°C) to securely stop the boiler preventing it from a "hot stop". The unit will then automatically shut down the heating loop.
3. Place the foot pedal on the ground, in a safe location close to the unit, to proceed coiling the hoses back into the unit's drum.
4. Reel in all hoses, ensuring an even distribution of the hoses in the drum to keep the unit's weight as even and centered as possible. Engage the reel lock pin.
5. Turn all the switches to the OFF position, and close all ball valves in the glycol manifolds, and fuel supply for a safe restart.

Startup

Ensure the machine is sitting as level as possible. Use grounding rod if possible.

1. Make sure all switches on the control panel are in the off position.



Power Source Selector Switch

2. Apply power to the machine. There are 2 methods of applying power to the machine. One method is by plugging an extension cord in to the passenger's side rear of the machine from an external 120Volt ac power source. If the Thawzall machine has a generator package installed, the generator can be used to power the machine. The generator will have a twist lock plug plugged in to the front panel of the machine on the driver's side front panel. Below are pictures of the 2 methods for powering the machine. Using Power Source switch select whether you are running off generator or line power.



3. Once there is power to the machine, start setting up at least one hose or all 5 hoses to get circulation established. Use the power out function of the hose reel to aid in pulling the hose off of the hose reel. There are switches for the hose reel operation on the control panel. Look inside the back doors to your right to find the hose reel control switches. These 2 switches control the hose reel operation. Select hose out and press the foot switch and the hose reel will begin to unwind the hose. Alternatively the hose can be freewheeled by removing the reel lock pin and releasing the belt tension with the tensioner knob. Remember each hose is 600 feet in length and each end of a 600 foot hose needs to be connected to a supply and return disconnect on the manifold. After connecting both ends of a 600 foot hose to the manifold, open the ball valves for the disconnect that the hose is connected to. Below are pictures of the switches for the hose reel and an example of a hose connected to the manifold.

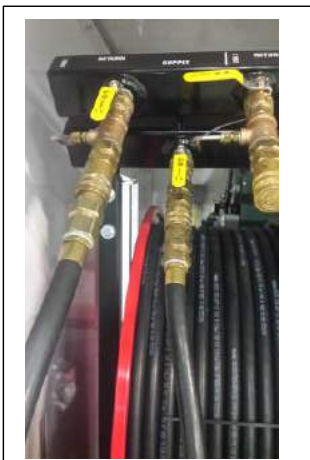

4. After connecting a hose or hoses to the manifold, the ball valves inside the passenger's side door need to be opened. There are 3 flange style ball valves that need to be open. Also make sure to open the yellow handled ball valve on the gray expansion tank if it is not already open. Next establish circulation by turning the main power switch to the on position. There is a sight flow indicator inside the passenger's side door. The sight flow indicator is to the left as you look in the door and down by the floor of the trailer. The impeller wheel should spin when flow is established. Also, there are two automatic air bleeders that need to be opened. The automatic air bleeders are made out of brass. One automatic air bleeder is located on the return manifold and the other automatic air bleeder is inside the passenger's side door on top of the furnace by the stove pipe.



5. Open the fuel valve on the fuel tank, turn the main power switch on the control panel to the “ON” position and this will start the pump and send power to the furnace. After a 30 second delay the furnace will attempt to light .

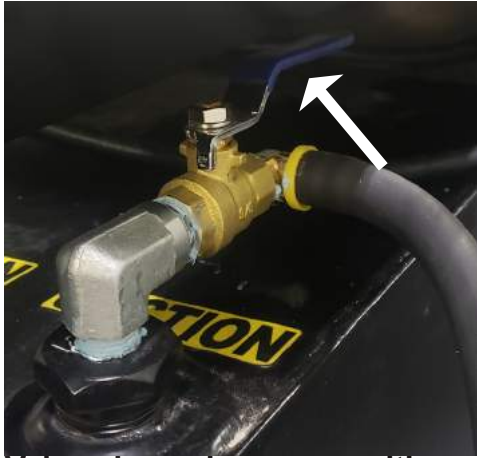

Valve shown in open position



6. The TCH250 uses a mixing valve to control the output temperature to the supply manifold. The valve is electronically controlled by the PLC. .

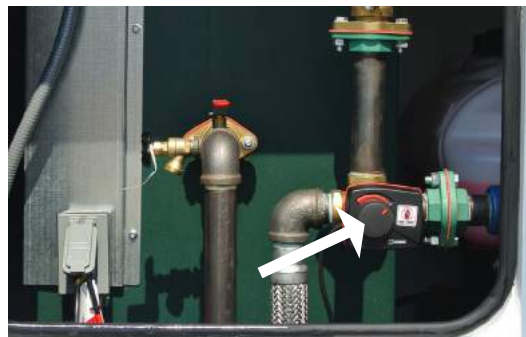

The temperature setpoint is adjustable by the user from 70° F to 180° F. The PLC display screen will display the setpoint and current temperatures of each of the return ports.



Shut Down

When the job is done and it is time to shut the machine down turn the main power switch to the off position and the unit will automatically go into “Cool Down” mode shown with indicator light. Doing so removes power from the furnace and allows the heat transfer fluid to continue to circulate until the furnace cools down to at least 130° F on the temperature/pressure gauge on the face of the furnace. Doing this will avoid hot shut down on the boiler and allow the hoses to cool down so they are not hot to the touch but still pliable enough for winding up the hose for storage.



Once the temperature on the temperature / pressure gauge on the face of the furnace has reached at least 140 °F you can turn off the generator or disconnect from shore power. Close the fuel valve on the fuel tank. Closing the fuel valve on the fuel tank will help prevent air from getting in to the fuel supply to the burner. If air get in the fuel supply it may cause the primary controller to go into a lock out condition the next time the machine is fired. Close the automatic air bleeders. Remember to re-open the automatic air bleeders when setting the machine up at the next job. Close the ball valves on the manifold.



Open

Closed

Hose Reel Operation

The TCH 250 has hose reel control switches on the control panel. The hose reel can be powered both to extend or retract the hose reel selected by the reel direction switch. The reel can also be released for optional free-wheeling for manual hose deployment. Disconnect the first hose to wind up. When the hoses are stored on the hose reel they are connected together for ease of winding up. Turn the hose reel switch to the On position and select In. Press the foot switch to begin winding up on to the hose reel. When you get to the end of one of a hose and connect the next hose to it remember to leave some slack in the hose at this junction when rolling the hoses up. This will help prevent stress on the ends of the hoses. Once all hoses are reeled up, engage the reel lock pin to prevent the reel from turning during transport.



Reel Lock Pin

Unspooling: To spool out the hose, release the lock pin as shown in the picture below. Loosen the belt tension knob to allow the hose reel to free-wheel out. Start pulling the hose off the reel, if you find that the reel is free-wheeling too fast, increase the drag tension by turning the knob clockwise.

Spooling In: To spool the hose onto the reel, turn the selector switch on the control panel to the hose reel position. Select "IN" on the hose reel direction switch. Adjust the belt tension knob by turning clockwise. Depress the foot switch to begin spooling in the hose. If you find the reel is not pulling the hose in and the belt is slipping, increase the belt tension, with the belt tensioning knob.



Belt Tension Knob

Boiler

At times the TCH250 will display a low level alarm. This is a normal occurrence and is mostly due to a loss of pressure in the closed loop when setting up the unit at a new jobsite. When this happens the hydronic loop must be refilled by following these steps.

1. Open the ball valve on the discharge side of the fill pump.
2. Loosen the bleeder valve cap half a turn. (located on the passenger side of the boiler)
3. Press and hold the momentary switch until the pressure/temperature gauge located on the boiler shows between 5-10 PSI. * NEVER EXCEED 10PSI*
4. Release the momentary switch and tighten up the bleeder cap.
5. Press the reset button on the low level switch located on top of the boiler, the yellow light should now be on.

The unit will restart automatically.

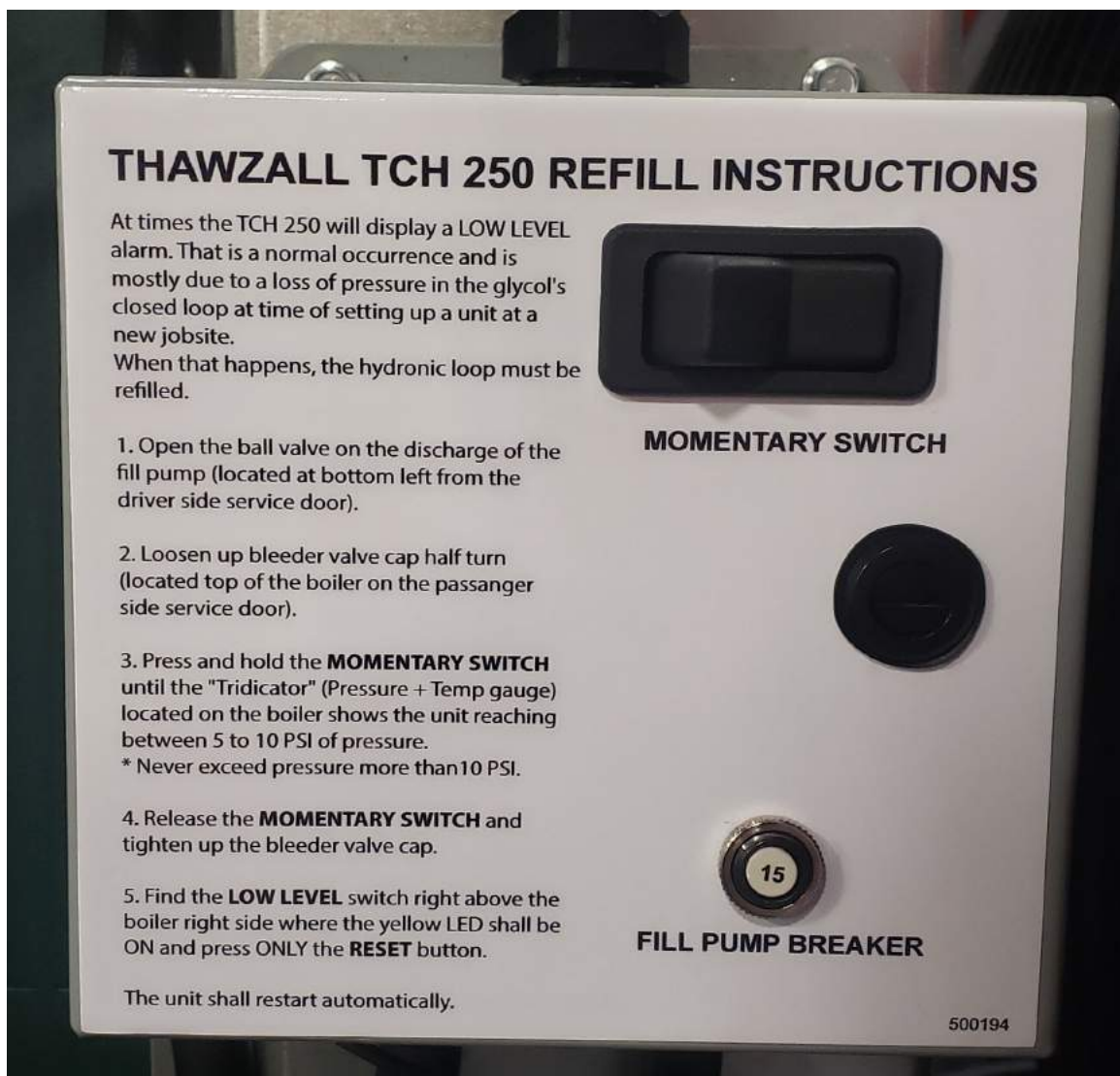

Electric Heater

Inside the cabinet you will find a 1000 watt electric heater, this is used to keep the fuel system warm and put extra load on the generator to prevent wet stacking (a condition caused in diesel engines when there isnt enough load and the engine doesnt get hot enough to burn off carbon deposits).

When the TCH250 is pwered by an onboard generator this heater will automatically run.



GROUND THAW SETUP CHARTS

TEMPERATURE: 30° F or higher/-1° C
LAYERS OF BLANKETS TO USE: SINGLE (R6 insulation factor) SOIL CONDITION: Gravel or Sand
(good drainage)

Frost Depth		-			
	12"	24"	36"	48"	60"
Hose Spacing**	24"	16"	16"	16"	16"
Hours to run	24	48	72	96	120

**Hose spacing is measured inches on center

TEMPERATURE: 30° F or higher/-1° C
LAYERS OF BLANKETS TO USE: SINGLE (R6 insulation factor) SOIL CONDITION: Clay or Silt
(poor to moderate drainage)

Frost Depth	12"	24"	36"	48"	60"
Hose Spacing"	16"	16"	16"	16"	16"
Hours to run	24	48	72	96	120

**Hose spacing is measured inches on center

TEMPERATURE: 15° F to 30° F/-9° C to -1° C
LAYERS OF BLANKETS TO USE: SINGLE (R6 insulation factor) SOIL CONDITION:
Gravel or Sand (good drainage)

Frost Depth	12"	24"	36"	48"	60"
Hose Spacing'	24"	24"	24"	24"	24"
Hours to run	24	48	72	96	120

Frost Depth	12"	24"	36"	48"	60"
Hose Spacing'	24"	24"	24"	24"	24"
Hours to run	24	48	72	96	120

**Hose spacing is measured inches on center

GROUND THAW SETUP CHARTS, cont.

TEMPERATURE: 0° F to 15° F / -18° C to -9° C

LAYERS OF BLANKETS TO USE: DOUBLE (R12 insulation factor) SOIL CONDITION: Gravel or Sand (good drainage)

Frost Depth	12"	24"	36"	48"	60"
Hose Spacing	24"	24"	24"	24"	24"
Hours to run	24	48	72	96	120

"Hose spacing is measured inches on center

TEMPERATURE: 0° F to 15° F / -18° C to -9° C

LAYERS OF BLANKETS TO USE: DOUBLE (R12 insulation factor) SOIL CONDITION: Clay or Silt (poor to moderate drainage)

Frost Depth	12"	24"	36"	48"	60"
Hose Spacing**	16"	16"	16"	16"	16"
Hours to run	24	48	72	96	120

**Hose spacing is measured inches on center

TEMPERATURE: -20° F to 0° F / -28° C to -18° C

LAYERS OF BLANKETS TO USE: DOUBLE (R12 insulation factor) SOIL CONDITION: Gravel or Sand (good drainage)

Frost Depth	12"	24"	36"	48"	60"
Hose Spacing**	16"	16"	16"	16"	16"
Hours to run	24	48	72	96	120

"Hose spacing is measured inches on center

TEMPERATURE: -20° F to 0° F / -28° C to -18° C

LAYERS OF BLANKETS TO USE: DOUBLE (R12 insulation factor) SOIL CONDITION: Clay or Silt (poor to moderate drainage)

Frost Depth	12"	24"	36"	48"	60"
Hose Spacing"	16"	16"	16"	16"	16"
Hours to run	24	48	72	96	120

"Hose spacing is measured inches on center

GROUND THAW SETUP CHARTS, cont.

TEMPERATURE: -20° F or lower/ -29° C or lower
LAYERS OF BLANKETS TO USE: DOUBLE (R12 insulation factor) SOIL CONDITION:
Gravel or Sand (good drainage)

Frost Depth	12"	24"	36"	48"	60"
Hose Spacing**	16"	16"	16"	16"	16"
Hours to run	24	48	72	96	120

"Hose spacing is measured inches on center

TEMPERATURE: -20° F to lower/ -28° C or lower
LAYERS OF BLANKETS TO USE: DOUBLE (R12 insulation factor) SOIL CONDITION:
Clay or Silt (poor to moderate drainage)

Frost Depth	12"	24"	36"	48"	60"
Hose Spacing"	16"	16"	16"	16"	16"
Hours to run	24	48	72	96	120

"Hose spacing is measured inches on center

THAW

When moisture freezes in the soil, it requires 143 BTU's per pound to thaw the ground. Shown are 4 types of soil and their thawing requirements:



Gravel

up to 1,001 BTU's required to melt ice



Sand

up to 2,574 BTU's required to melt ice



Clay

up to 3,146 BTU's required to melt ice



Silt

up to 7,436 BTU's required to melt ice

CURE

Concrete cures slowly due to cold temperatures. Here's how temperature affects the concrete curing process:

Curing of Concrete vs. Time

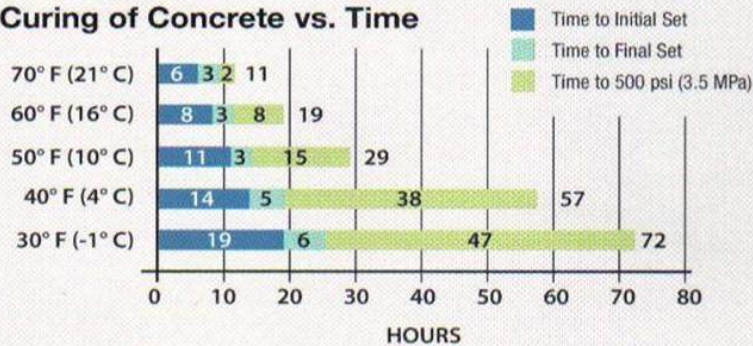

Performance

Thaw and Cure performance in the field is affected by a wide range of factors to include soil type, density of frozen ice in the soil, hose spacing, thermal rating of the covering insulating blankets, and ambient temperatures.

Heat performance in interior spaces is also affected by several factors to include outside ambient temperatures, heat loss through walls and ceiling, and the volume of the space to be heated.

In general, with proper hose spacing and adequate insulation, the operator should be able to THAW about one foot of soil per day. Consult our Thawzall Technical Support personnel with questions regarding proper hose spacing. 888.757.3545

HOSE CAPACITY FILL CHART

HOSE SIZE	GALLONS PER FOOT
(Inside dia.)	
1/2	0.016
5/8	0.019
3/4	0.023
1.00	0.04
1 1/4	0.063

DISCONNECT MAINTENANCE

1. Water and dirt may get into a disconnect piece and cause it to corrode or to work improperly. It is vital that dis-connects be cleaned and lubricated at least once per season or when they get dirty. Failure to maintain disconnects properly will void the warranty.

To clean disconnects:

- Use a mild soap and water or all-purpose cleaner like dish soap or Windex
- Use a nylon bristle brush to scrub the couplers. (Do not use a metal brush.)
- Rinse and wipe parts dry □ Allow parts to dry

To lubricate disconnects:

Use only Silicon based products that do not contain any penetrating oils like LPS or Lubrimatic. Silicone based lubricants are available at automotive parts stores or farm equipment dealerships.

Apply silicone lubricant liberally.

DO NOT USE WD-40 OR SIMILAR PRODUCTS THAT CONTAIN PENETRATING OIL.

Silicone based lubricants will displace water trapped in the disconnects and will not damage the seals inside.

For repair of the male coupler, please use the following 6 step procedure

1. Place the male coupler in a vise with the valve end up
2. Using a drift punch or other dull or flat tool, push the valve into the coupler body
3. Wedge a steel pick in between the valve and the body to hold the valve down
4. Remove the damaged O-ring and back-up ring with another pick
5. Clean the O-ring seat and install the back-up ring
6. Lubricate the O-ring seal and install it. Then release the valve by removing the pick

Troubleshooting

The Thazall TCH250 is a self-contained glycol heating system that can be used to thaw frozen ground or maintain a work area at a constant temperature. It is a simple system that requires minimal maintenance.

In the following trouble shooting section, we have listed many of the problems, causes and solutions to the problems which you may encounter.

If you encounter a problem that is difficult to solve, even after having read through this trouble shooting section, please contact your authorized dealer, distributor or the factory. Before you call, please have this Operator's Manual and the serial number from your machine ready.

PROBLEM	CAUSE	SOLUTION
Burners won't start.	No fuel.	Fill the fuel tank.
	No power.	Plug machine in and turn on. Breaker tripped. Reset breaker.
	Low glycol.	Fill glycol reservoir/pressurize system
	Switch off.	Pull out Emergency Stop switch

NOTE: For the burners to be able to fire, three conditions must be met.

- 1) The Pressure switch on the circulation loop must see pressure. (gray plastic box on circ pump)
- 2) The low glycol sensor must sense glycol. (blue box on glycol tank)
- 3) The aquastat temperature has to allow the call for heat, by being below 230°F. This condition would be very rare, and should only trip off if there is not enough flow through the coil or the burner is burning too hot.

Buner gives off black smoke.	Wrong fuel/air mixture.	Reset air mixture.
	Fouled burner.	Clean burners.
	Plugged fuel filter(s).	Change filter(s).
Reel won't move.	No power.	Turn power on. Reset circuit breaker.
	Drive belt loose.	Adjust drive belt tension.

BECKETT BURNER GENISYS™ CONTROL

Basic Features:

Three indicator lights:

- Red reset button/lockout light
- Pump Prime
- Green flame/recycle light

Limited Reset

- Recurring lockouts without a complete heat cycle puts control in restricted (hard lockout) mode

Limited Recycle

- If flame is established and then lost, the control will recycle until the cumulative time trial for ignition budget is exhausted and will then go into hard lockout. This prevents excessive oil accumulation in the appliance

Valve on delay—15 seconds

Motor-off delay—none

Sequence of Operation

1. Standby
2. Valve-on delay
3. Trial for ignition
4. Lockout
5. Ignition carryover
6. Run
7. Recycle
8. Motor-off delay
9. Pump prime

OPERATING STATES:

STANDBY

- The burner is idle, waiting for a call for heat. When a call for heat is initiated, there is a ½ second delay while the control performs a safe start check

VALVE-ON DELAY (pre-time)

- The igniter and motor are on while the fuel solenoid valve remains de-energized—typically 15 seconds. Allows the burner to establish air flow and brings the pump to full speed, helping to keep ignitions smooth and clean

TRIAL FOR IGNITION

The oil solenoid valve is energized. A flame should be established within the factory set trial for ignition time (also known as “lockout time”) 15 seconds on the Genisys control

OPERATING STATES, cont.:

IGNITION CARRYOVER

- Once flame is established, the igniter remains on for 10 additional seconds to ensure flame stability before shutting off

RUN

- The flame is sustained until the call for heat is satisfied or safety limit shuts down burner

MOTOR-OFF DELAY (post-time)

- If applicable, the oil solenoid valve is de-energized and the motor continues to run for the preset motor-off delay time. Cools the nozzle to prevent after drip, and expels fumes and combustion
- If the cad cell detects flame in the Motor-Off Delay mode, the control goes into the standby mode. This is to prevent a failed fuel valve from keeping the flame burning

LOCKOUT—the control has shut down the burner for one of the following safety reasons:

- Trial for ignition (lockout) time expires without flame being established
- Cad cell detects flame at the end of valve-on delay
- Recycle time budget expires
- Relay check failure
- You can **NOT** reset the control by interrupting line voltage

RECYCLE

- If the flame is lost while the burner is firing, the control shuts down the burner, enters a 60 second recycle delay, and repeats the ignition sequence. The control will continue to recycle each time the flame is lost, until it reaches a preset cumulative trial for ignition time allotment. The control will then go into Hard Lockout instead of recycle. This feature prevents excessive accumulation of oil in the appliance firing chamber.

PUMP PRIME

- Enter Pump Prime mode by holding down the reset button while in the trial for ignition until the control powers down the equipment. Then oppress the reset button again to enter Pump Prime mode
- The igniter and motor are on 4 minutes, and the cad cell is disregarded. This allows the technician to prime the pump without having to jumper the cad cell
- Terminate the call for heat and the control will exit the pump prime mode and resume normal operation.
- You can remove the control from the Pump Prime mode by holding the reset button for 1 second. The control will return to Standby mode.

OPERATING STATES, cont.:

DISABLE FUNCTION

- Press and hold red reset button for 1 second at any time to disable the burner
- When you release the reset button the burner will return to normal operation
- Genisys control has limited reset
- Initial lockouts result in “soft” lockout.

Red light flashing—click the red reset button to restart

- Recurring lockouts without completing a heat cycle will result in Restricted (“hard”) lockout.

Red light on steady—hold the red reset button 15 seconds until the yellow light turns on. You can NOT reset the control by interrupting line voltage.

PUMP PRIME MODE

- Prepare the burner for priming
- Initiate a call for heat
- After the burner starts, press and hold the reset button until the yellow light turns on. (15 seconds)
- Release the reset button. The yellow light will turn off and the burner will start again
- At burner start up, click the reset button
- Enters 4-minute dedicated pump prime mode, with motor and igniter on, and oil valve energized. The yellow light is on when in the pump prime mode
- Terminate the call for heat and the control will exit the pump prime mode and resume normal operation

Alarms

ALARM SCREEN

In the event of a problem any active alarms will automatically be displayed. Use the [up] / [down] keys to scroll through the list of active alarms, See next page for alarms list.



Alarm Code – The alarm code is a unique identifier for each alarm condition. For a complete list of possible alarm conditions see “Alarm list” section of the manual.

Alarm Description - In addition to the alarm code, each alarm condition has a unique descriptor. For a complete list of possible alarm conditions see “Alarm list” section of the manual.

Alarm Number - This indicates where you are in the list of active alarms starting with the most recent.

Total Active Alarms – Indicates how many alarms are currently active in the list.

Time / Date of Alarm – This shows the time that the alarm was activated

When an active alarm is present, the [Alarm] key will flash red. Pressing the key will take the operator to the main alarm screen:



ALARM LIST			
Index	Reset	Alarm Description	Alarm Action
0	MAN	Memory Failure	All functions stopped, replace PLC
1	MAN	Memory Error	All functions stopped, replace PLC
2	AUTO	Emergency Stop	Interrupts power to all devices
3	AUTO	Low Glycol Level	Stops pump and boiler
4	MAN	Circulating Pump Service Hours	Alarm message generated, no action take
5	MAN	Burner Service Hours	Alarm message generated, no action take
6	AUTO	Boiler Over Temperature	Boiler temperature above software limit
7	AUTO	Fuel Warning	Alarm message generated, no action take
8	AUTO	Supply Temp Probe Fail	Temperature Sensor Reading Error
9	AUTO	Return Temp Probe Fail	Temperature Sensor Reading Error
10	AUTO	Return Temp Probe Fail	Temperature Sensor Reading Error
11	AUTO	Return Temp Probe Fail	Temperature Sensor Reading Error
12	AUTO	Return Temp Probe Fail	Temperature Sensor Reading Error
13	AUTO	Return Temp Probe Fail	Temperature Sensor Reading Error
14	AUTO	Return Temp Probe Fail	Temperature Sensor Reading Error
15	AUTO	Boiler Temp Probe Fail	Temperature Sensor Reading Error

ALARM RESET

Alarms can be reset by the operator through the alarm screen. This is done by pressing and holding the [Alarm] for 3 seconds:



ALARM LOGGER

The alarm logger contains a list of historical alarm events for the purpose of troubleshooting. The logger can be accessed through the alarm screen by pressing the [Enter] key:

The records can be scrolled through using the up and down keys.



MAINTENANCE SAFETY

1. Review the Operator's Manual and all safety items before working with, maintaining or operating the Heater.
2. Place all controls in their OFF position, disconnect power cords and wait for all moving parts to stop before servicing, adjusting or maintaining.
3. Have a first-aid kit available for use should the need arise and know how to use it.
 - Keep service area clean and dry.
 - Be sure electrical outlets and tools are properly grounded.
 - Use adequate light for the job at hand.
4. Keep hands, feet, clothing and hair away from all moving and/or rotating parts of the hose reel and drive system.
5. Always wear heavy gloves to prevent burns when handling hot components. Wait until burners, coils and glycol system components have cooled before working on them.
6. Do not attempt any adjustment or maintenance to any system of the Heater unless the power wires are disconnected.
7. Make sure that all guards, shields and hoods are properly installed and secured before operating the Heater.
8. Securely support the machine using blocks or safety stands before working beneath it or changing tires.
9. Store and transfer diesel fuel, solvents, cleaners or any flammable liquids only in safety standard approved containers.

FLUIDS AND LUBRICANTS

1. **Grease:**
Use SAE multipurpose high temperature grease or a multipurpose lithium base grease.
2. **Fuel:**
#1 or #2 Diesel Fuel
3. **Glycol:**
Use only Tamarack approved glycol for all operating conditions. Polypropylene 50% glycol 50% water. Do not mix or combine other types.
4. **Gearbox Oil:**
Use an SAE 80W90 oil for all operating conditions. Do not mix oil types or viscosities. Gearbox Capacity: 1.5 US qts.
5. **Storing Lubricants and Fluids:**
Your machine can operate at top efficiency only if clean lubricants are used. Use clean containers to handle all fluids. Store them in an area protected from dust, moisture and other contaminants.

GREASING

Use the Maintenance Checklist provided to keep a record of all scheduled maintenance.

1. Use only a hand-held grease gun for all greasing. An air-powered greasing system can damage the seals on bearings and lead to early failures.
2. Wipe grease fitting with a clean cloth before greasing to avoid injecting dirt and grit.
3. Replace and repair broken fittings immediately.
4. If fittings will not take grease, remove and clean thoroughly. Also clean lubricant passage. Replace fitting if necessary.

Maintenance Chart

Description	Operation	Every 750 Hours	Monthly	Annually
Burner Nozzle	Change	X		
Burner Electrodes	Change	X		
Burner Fuel filter	Change	X		
Grease Axle Hubs	Service		X	
Grease Reel Bearings	Service		X	
Reel Gear Box	Check			X

Service Parts

Item	Part #
Burner	
1.75 80° A GPH Nozzle	T10628
Fuel pump	T10465
Electrode Kit	T10390
Cad cell	T10525
transformer	T10405
Primary Control	T10660
Fuel filter	445157
Circulation Pump 1/2 HP	
Mechanical Seal Kit	449063
Pump Assembly	441185

Burner Maintenance



DO NOT TAMPER WITH THE UNIT OR CONTROLS - CALL YOUR SERVICE PERSONNEL.

To ensure continued reliable operation, a qualified service technician must service this burner every **750 hours**.

More frequent service intervals may be required in dusty or adverse environments.

Operation and adjustment of the burner requires technical training and skillful use of combustion test instruments and other test equipment.



Tools Required

- 5/16" wrench
- 3/8" wrench
- 7/16" wrench
- 5/8" wrench
- 3/4" wrench
- pliers



CHANGING FUEL NOZZLE AND ELECTRODES

Annually or every 750 hours (or more often if fuel quality is poor) the fuel nozzles and electrodes should be changed. To change, follow this procedure:

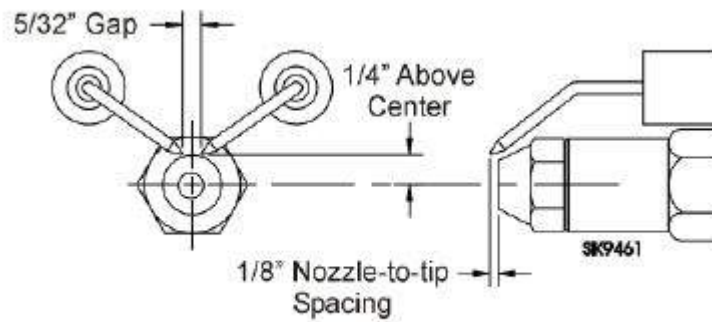
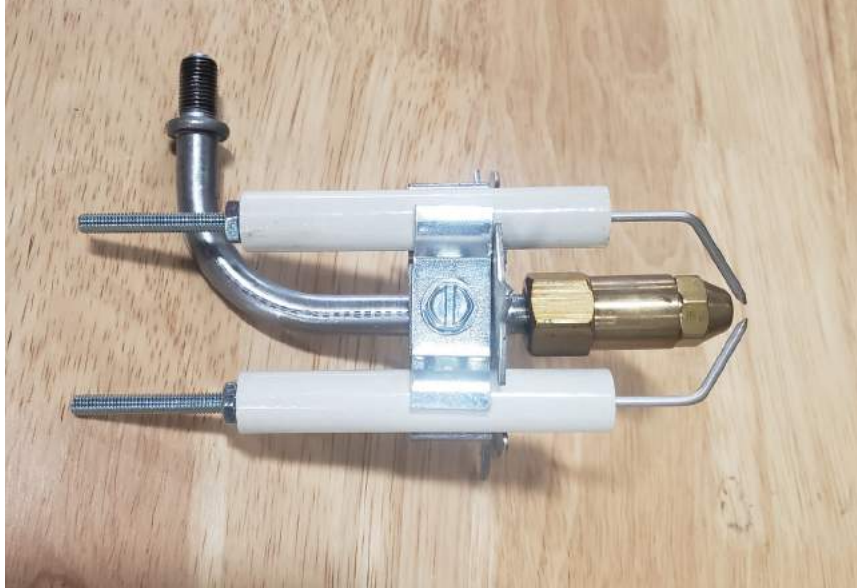

Check/adjust electrodes

Check the electrode tip settings. Adjust if necessary to comply with the dimensions shown. To adjust, loosen the electrode clamp screw and slide/rotate electrodes as necessary. Securely tighten the clamp screw when finished.

Removing Nozzle Line Assembly

1. Turn off power before servicing.



2. Disconnect oil connector tube from nozzle line.

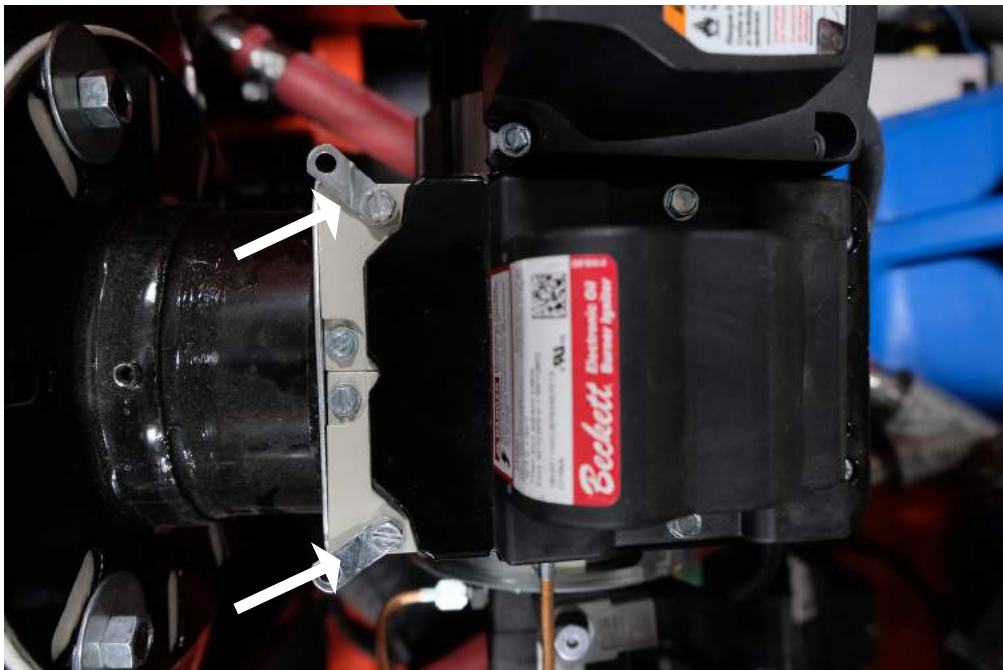

3. Loosen the two screws securing igniter retaining clips and rotate both clips to release igniter baseplate. Then tilt igniter back on its hinge.



4. Remove splined nut.



5. Remove nozzle line assembly from burner, being careful not to damage the electrodes or insulators while handling. To ease removal of the assembly rotate assembly 180° from installed position after pulling partially out of tube.

*To replace the nozzle assembly, reverse the above steps.

Complete Drawer Assembly Removed

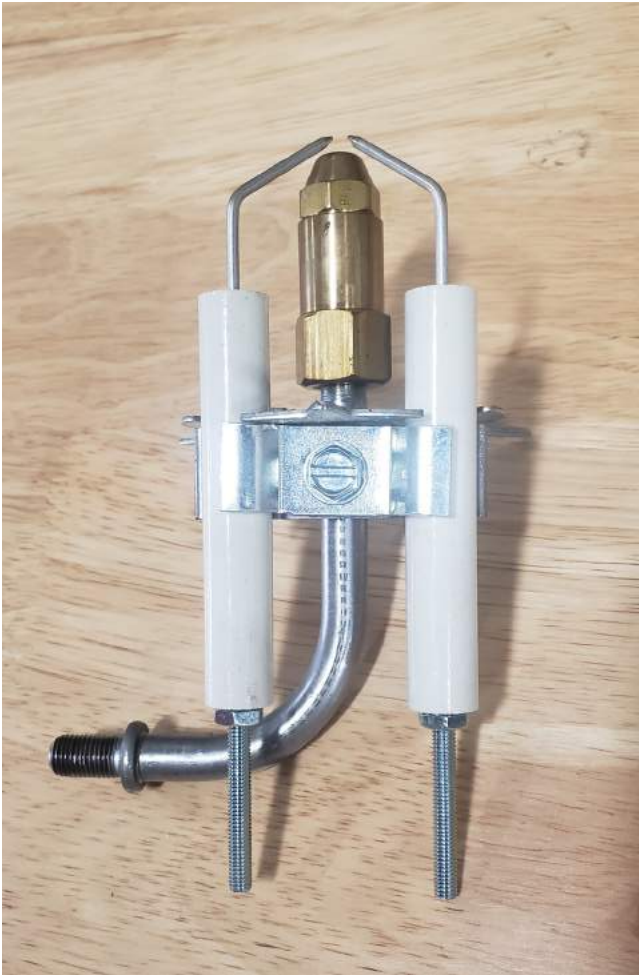

Nozzle and Electrodes Removed



Filters



Fuel Filter:

The burner fuel circuit is designed with a filter to remove contaminants and water from the fuel. Change filter every 750 burner hours to keep the system clean. Change more frequently if contaminants are introduced into the system during re-fuelling. In the bottom of each of the filter is a knob that can be loosened to drain water out that gathers in the bottom of the filter.

Note: Put a pan under the fuel filter when changing them, to capture any fuel that may leak or drip. Dispose all fuel related items responsibly.

TCH250 Specifications

General Capacities and Component Specifications

Height	90 in.
Width	84 in.
Length (from hitch)	172 in.
Ground Clearance	12 in.
Weight (w/ glycol)	5600 lbs.
Weight (w/ fuel and glycol)	6580 lbs.
Fuel Capacity	138 US gal.
Glycol / water capacity	83 US gal 50/50 Mix
Hoses	5 x 600 ft. 3.4" ID
Circulation manifold	5 X 3/4" quick disconnects 1 X 1" quick disconnect
Burner	250,000 BTUH Oil Fired Burner
Pumps	1 - 1/2 HP Centrifugal Circulating Pump
Reel motor	1 - 1/2 HP Motor
Axles	1 - 7000 lb. rated w/ Electric Brakes
Tires	235/80R/16
Tire inflation pressure	80 psi.
Torque of wheel nuts	120 ft-lbs
Hitch	2-5/16" Ball, alternatively Pintle
Tie Downs	4 - For Transporting

Performance Specifications

Net Heat Input	280,000 BTUH
Fuel Consumption	2.06 US GPH
Fuel Requirement	#1 or #2 Diesel Fuel
Run Time	65 hours @ 100% Burn Time
Boiler Pressure	5 Psi
Fuel Pump Pressure	140 psi
Maximum Thawing Area	6000 ft ²
Maximum Curing Area	12000 ft ²
Nozzle	Delavan 1.75 GPH 80° A
Electrical Requirement	1 x 20 Amp x 120 V AC



SAFETY DATA SHEET

THE DOW CHEMICAL COMPANY

Product name: DOWFROST™ Heat Transfer Fluid

Issue Date: 04/09/2015

Print Date: 04/10/2015

THE DOW CHEMICAL COMPANY encourages and expects you to read and understand the entire (M)SDS, as there is important information throughout the document. We expect you to follow the precautions identified in this document unless your use conditions would necessitate other appropriate methods or actions.

1. IDENTIFICATION

Product name: DOWFROST™ Heat Transfer Fluid

Recommended use of the chemical and restrictions on use

Identified uses: Intended as a heat transfer fluid for closed-loop systems. This product is acceptable for use where there is possibility of incidental food contact and as a product for use in the immersion or spray freezing of wrapped meat and packaged poultry products. We recommend that you use this product in a manner consistent with the listed use. If your intended use is not consistent with the stated use, please contact your sales or technical service representative.

COMPANY IDENTIFICATION

THE DOW CHEMICAL COMPANY
2030 WILLARD H DOW CENTER
MIDLAND MI 48674-0000
UNITED STATES

Customer Information Number:

800-258-2436

SDSQuestion@dow.com

EMERGENCY TELEPHONE NUMBER

24-Hour Emergency Contact: 800-424-9300

Local Emergency Contact: 989-636-4400

2. HAZARDS IDENTIFICATION

Hazard classification

This material is not hazardous under the criteria of the Federal OSHA Hazard Communication Standard 29CFR 1910.1200.

Other hazards

no data available

3. COMPOSITION/INFORMATION ON INGREDIENTS

Chemical nature: Glycol

This product is a mixture.

Component	CASRN	Concentration
Propylene glycol	57-55-6	> 95.0 %
Dipotassium hydrogen phosphate	7758-11-4	< 3.0 %
Water	7732-18-5	< 3.0 %

4. FIRST AID MEASURES

Description of first aid measures

General advice: If potential for exposure exists refer to Section 8 for specific personal protective equipment.

Inhalation: Move person to fresh air; if effects occur, consult a physician.

Skin contact: Wash off with plenty of water.

Eye contact: Flush eyes thoroughly with water for several minutes. Remove contact lenses after the initial 1-2 minutes and continue flushing for several additional minutes. If effects occur, consult a physician, preferably an ophthalmologist.

Ingestion: No emergency medical treatment necessary.

Most important symptoms and effects, both acute and delayed: Aside from the information found under Description of first aid measures (above) and Indication of immediate medical attention and special treatment needed (below), any additional important symptoms and effects are described in Section 11: Toxicology Information.

Indication of any immediate medical attention and special treatment needed

Notes to physician: No specific antidote. Treatment of exposure should be directed at the control of symptoms and the clinical condition of the patient.

5. FIREFIGHTING MEASURES

Suitable extinguishing media: Water fog or fine spray. Dry chemical fire extinguishers. Carbon dioxide fire extinguishers. Foam. Alcohol resistant foams (ATC type) are preferred. General purpose synthetic foams (including AFFF) or protein foams may function, but will be less effective.

Unsuitable extinguishing media: Do not use direct water stream. May spread fire.

Special hazards arising from the substance or mixture

Hazardous combustion products: During a fire, smoke may contain the original material in addition to combustion products of varying composition which may be toxic and/or irritating. Combustion products may include and are not limited to: Carbon monoxide. Carbon dioxide.

Unusual Fire and Explosion Hazards: Container may rupture from gas generation in a fire situation. Violent steam generation or eruption may occur upon application of direct water stream to hot liquids.

Advice for firefighters

Fire Fighting Procedures: Keep people away. Isolate fire and deny unnecessary entry. Use water spray to cool fire exposed containers and fire affected zone until fire is out and danger of reignition has passed. Fight fire from protected location or safe distance. Consider the use of unmanned hose holders or monitor nozzles. Immediately withdraw all personnel from the area in case of rising sound from venting safety device or discoloration of the container. Burning liquids may be extinguished by dilution with water. Do not use direct water stream. May spread fire. Move container from fire area if this is possible without hazard. Burning liquids may be moved by flushing with water to protect personnel and minimize property damage.

Special protective equipment for firefighters: Wear positive-pressure self-contained breathing apparatus (SCBA) and protective fire fighting clothing (includes fire fighting helmet, coat, trousers, boots, and gloves). If protective equipment is not available or not used, fight fire from a protected location or safe distance.

6. ACCIDENTAL RELEASE MEASURES

Personal precautions, protective equipment and emergency procedures: Use appropriate safety equipment. For additional information, refer to Section 8, Exposure Controls and Personal Protection.

Environmental precautions: Prevent from entering into soil, ditches, sewers, waterways and/or groundwater. See Section 12, Ecological Information.

Methods and materials for containment and cleaning up: Small spills: Absorb with materials such as: Cat litter. Sawdust. Vermiculite. Zorb-all®. Collect in suitable and properly labeled containers. Large spills: Dike area to contain spill. Recover spilled material if possible. See Section 13, Disposal Considerations, for additional information.

7. HANDLING AND STORAGE

Precautions for safe handling: No special precautions required. Keep container closed. See Section 8, EXPOSURE CONTROLS AND PERSONAL PROTECTION.

Spills of these organic materials on hot fibrous insulations may lead to lowering of the autoignition temperatures possibly resulting in spontaneous combustion.

Conditions for safe storage: Do not store in: Galvanized steel. Opened or unlabeled containers. Store in original unopened container. See Section 10 for more specific information. Additional storage and handling information on this product may be obtained by calling your sales or customer service contact.

8. EXPOSURE CONTROLS/PERSONAL PROTECTION

Control parameters

Exposure limits are listed below, if they exist.

Component	Regulation	Type of listing	Value/Notation
Propylene glycol	US WEEL	TWA	10 mg/m ³

Exposure controls

Engineering controls: Use local exhaust ventilation, or other engineering controls to maintain airborne levels below exposure limit requirements or guidelines. If there are no applicable exposure limit requirements or guidelines, general ventilation should be sufficient for most operations. Local exhaust ventilation may be necessary for some operations.

Individual protection measures

Eye/face protection: Use safety glasses (with side shields).

Skin protection

Hand protection: Use gloves chemically resistant to this material when prolonged or frequently repeated contact could occur. Examples of preferred glove barrier materials include: Butyl rubber. Natural rubber ("latex"). Neoprene. Nitrile/butadiene rubber ("nitrile" or "NBR"). Polyethylene. Ethyl vinyl alcohol laminate ("EVAL"). Polyvinyl alcohol ("PVA"). Polyvinyl chloride ("PVC" or "vinyl"). NOTICE: The selection of a specific glove for a particular application and duration of use in a workplace should also take into account all relevant workplace factors such as, but not limited to: Other chemicals which may be handled, physical requirements (cut/puncture protection, dexterity, thermal protection), potential body reactions to glove materials, as well as the instructions/specifications provided by the glove supplier.

Other protection: Wear clean, body-covering clothing.

Respiratory protection: Respiratory protection should be worn when there is a potential to exceed the exposure limit requirements or guidelines. If there are no applicable exposure limit requirements or guidelines, wear respiratory protection when adverse effects, such as respiratory irritation or discomfort have been experienced, or where indicated by your risk assessment process. In misty atmospheres, use an approved particulate respirator. The following should be effective types of air-purifying respirators: Organic vapor cartridge with a particulate pre-filter.

9. PHYSICAL AND CHEMICAL PROPERTIES

Appearance

Physical state	Liquid.
Color	Colorless
Odor	Characteristic
Odor Threshold	No test data available
pH	10.0 50% <i>Literature</i>
Melting point/range	Not applicable to liquids
Freezing point	supercools
Boiling point (760 mmHg)	152 °C (306 °F) <i>Literature</i>
Flash point	closed cup 104 °C (219 °F) <i>Pensky-Martens Closed Cup ASTM D 93</i> (based on major component), Propylene glycol. open cup <i>Cleveland Open Cup ASTM D92</i> None
Evaporation Rate (Butyl Acetate = 1)	<0.5 <i>Estimated.</i>
Flammability (solid, gas)	Not applicable to liquids
Lower explosion limit	2.6 % vol <i>Literature</i> Propylene glycol.
Upper explosion limit	12.5 % vol <i>Literature</i> Propylene glycol.

Vapor Pressure	2.2 mmHg <i>Literature</i>
Relative Vapor Density (air = 1)	>1.0 <i>Literature</i>
Relative Density (water = 1)	1.05 at 20 °C (68 °F) / 20 °C <i>Literature</i>
Water solubility	100 % <i>Literature</i>
Partition coefficient: n-octanol/water	no data available
Auto-ignition temperature	371 °C (700 °F) <i>Literature</i> Propylene glycol.
Decomposition temperature	No test data available
Kinematic Viscosity	43.4 cSt at 20 °C (68 °F) <i>Literature</i>
Explosive properties	no data available
Oxidizing properties	no data available
Molecular weight	76.9 g/mol <i>Literature</i>

NOTE: The physical data presented above are typical values and should not be construed as a specification.

10. STABILITY AND REACTIVITY

Reactivity: no data available

Chemical stability: Stable under recommended storage conditions. See Storage, Section 7.
Hygroscopic

Possibility of hazardous reactions: Polymerization will not occur.

Conditions to avoid: Exposure to elevated temperatures can cause product to decompose. Generation of gas during decomposition can cause pressure in closed systems. Avoid direct sunlight or ultraviolet sources.

Incompatible materials: Avoid contact with: Strong acids. Strong bases. Strong oxidizers.

Hazardous decomposition products: Decomposition products depend upon temperature, air supply and the presence of other materials. Decomposition products can include and are not limited to: Aldehydes. Alcohols. Ethers. Organic acids.

11. TOXICOLOGICAL INFORMATION

Toxicological information on this product or its components appear in this section when such data is available.

Acute toxicity

Acute oral toxicity

Very low toxicity if swallowed. Harmful effects not anticipated from swallowing small amounts.

For the major component(s): Propylene glycol.
LD50, Rat, > 20,000 mg/kg

Acute dermal toxicity

Prolonged skin contact is unlikely to result in absorption of harmful amounts.

For the major component(s): Propylene glycol.
LD50, Rabbit, > 20,000 mg/kg

Acute inhalation toxicity

At room temperature, exposure to vapor is minimal due to low volatility. Mist may cause irritation of upper respiratory tract (nose and throat).

For the major component(s):
LC50, Rat, 4 Hour, vapour, 6.15 mg/l No deaths occurred following exposure to a saturated atmosphere.

Skin corrosion/irritation

Prolonged contact is essentially nonirritating to skin.
Repeated contact may cause flaking and softening of skin.

Serious eye damage/eye irritation

May cause slight temporary eye irritation.
Corneal injury is unlikely.

Sensitization

For the major component(s):
Did not cause allergic skin reactions when tested in humans.

For respiratory sensitization:
No relevant data found.

Specific Target Organ Systemic Toxicity (Single Exposure)

Evaluation of available data suggests that this material is not an STOT-SE toxicant.

Specific Target Organ Systemic Toxicity (Repeated Exposure)

In rare cases, repeated excessive exposure to propylene glycol may cause central nervous system effects.

Carcinogenicity

Similar formulations did not cause cancer in laboratory animals.

Teratogenicity

For the major component(s): Did not cause birth defects or any other fetal effects in laboratory animals.

Reproductive toxicity

For the major component(s): In animal studies, did not interfere with reproduction. In animal studies, did not interfere with fertility.

Mutagenicity

In vitro genetic toxicity studies were negative. For the major component(s): Animal genetic toxicity studies were negative.

Aspiration Hazard

Based on physical properties, not likely to be an aspiration hazard.

12. ECOLOGICAL INFORMATION

Ecotoxicological information on this product or its components appear in this section when such data is available.

Toxicity

Propylene glycol

Acute toxicity to fish

Material is practically non-toxic to aquatic organisms on an acute basis (LC50/EC50/EL50/LL50 >100 mg/L in the most sensitive species tested).
LC50, Oncorhynchus mykiss (rainbow trout), static test, 96 Hour, 40,613 mg/l, OECD Test Guideline 203

Acute toxicity to aquatic invertebrates

LC50, Ceriodaphnia dubia (water flea), static test, 48 Hour, 18,340 mg/l, OECD Test Guideline 202

Acute toxicity to algae/aquatic plants

ErC50, Pseudokirchneriella subcapitata (green algae), 96 Hour, Growth rate inhibition, 19,000 mg/l, OECD Test Guideline 201

Toxicity to bacteria

NOEC, Pseudomonas putida, 18 Hour, > 20,000 mg/l

Chronic toxicity to aquatic invertebrates

NOEC, Ceriodaphnia dubia (water flea), semi-static test, 7 d, number of offspring, 13,020 mg/l

Dipotassium hydrogen phosphate

Acute toxicity to fish

Material is practically non-toxic to aquatic organisms on an acute basis (LC50/EC50/EL50/LL50 >100 mg/L in the most sensitive species tested).
LC50, Leuciscus idus (Golden orfe), static test, 48 Hour, > 900 mg/l, Method Not Specified.

Persistence and degradability

Propylene glycol

Biodegradability: Material is readily biodegradable. Passes OECD test(s) for ready biodegradability. Biodegradation may occur under anaerobic conditions (in the absence of oxygen).

10-day Window: Pass

Biodegradation: 81 %

Exposure time: 28 d

Method: OECD Test Guideline 301F or Equivalent

10-day Window: Not applicable

Biodegradation: 96 %

Exposure time: 64 d

Method: OECD Test Guideline 306 or Equivalent

Theoretical Oxygen Demand: 1.68 mg/mg

Chemical Oxygen Demand: 1.53 mg/mg

Biological oxygen demand (BOD)

Incubation Time	BOD
5 d	69.000 %
10 d	70.000 %
20 d	86.000 %

Photodegradation

Atmospheric half-life: 10 Hour

Method: Estimated.

Dipotassium hydrogen phosphate

Biodegradability: Biodegradation is not applicable.

Bioaccumulative potential

Propylene glycol

Bioaccumulation: Bioconcentration potential is low (BCF < 100 or Log Pow < 3).

Partition coefficient: n-octanol/water(log Pow): -1.07 Measured

Bioconcentration factor (BCF): 0.09 Estimated.

Dipotassium hydrogen phosphate

Bioaccumulation: No bioconcentration is expected because of the relatively high water solubility.

Mobility in soil

Propylene glycol

Given its very low Henry's constant, volatilization from natural bodies of water or moist soil is not expected to be an important fate process.

Potential for mobility in soil is very high (Koc between 0 and 50).

Partition coefficient(Koc): < 1 Estimated.

Dipotassium hydrogen phosphate

No relevant data found.

13. DISPOSAL CONSIDERATIONS

Disposal methods: DO NOT DUMP INTO ANY SEWERS, ON THE GROUND, OR INTO ANY BODY OF WATER. All disposal practices must be in compliance with all Federal, State/Provincial and local laws and regulations. Regulations may vary in different locations. Waste characterizations and compliance with applicable laws are the responsibility solely of the waste generator. AS YOUR SUPPLIER, WE HAVE NO CONTROL OVER THE MANAGEMENT PRACTICES OR MANUFACTURING PROCESSES OF PARTIES HANDLING OR USING THIS MATERIAL. THE INFORMATION PRESENTED HERE PERTAINS ONLY TO THE PRODUCT AS SHIPPED IN ITS

INTENDED CONDITION AS DESCRIBED IN MSDS SECTION: Composition Information. FOR UNUSED & UNCONTAMINATED PRODUCT, the preferred options include sending to a licensed, permitted: Recycler. Reclaimer. Incinerator or other thermal destruction device.

14. TRANSPORT INFORMATION

DOT

Not regulated for transport

Classification for SEA transport (IMO-IMDG):

**Transport in bulk
according to Annex I or II
of MARPOL 73/78 and the
IBC or IGC Code**

Not regulated for transport
Consult IMO regulations before transporting ocean bulk

Classification for AIR transport (IATA/ICAO):

Not regulated for transport

This information is not intended to convey all specific regulatory or operational requirements/information relating to this product. Transportation classifications may vary by container volume and may be influenced by regional or country variations in regulations. Additional transportation system information can be obtained through an authorized sales or customer service representative. It is the responsibility of the transporting organization to follow all applicable laws, regulations and rules relating to the transportation of the material.

15. REGULATORY INFORMATION

OSHA Hazard Communication Standard

This product is not a "Hazardous Chemical" as defined by the OSHA Hazard Communication Standard, 29 CFR 1910.1200.

Superfund Amendments and Reauthorization Act of 1986 Title III (Emergency Planning and Community Right-to-Know Act of 1986) Sections 311 and 312

This product is not a hazardous chemical under 29CFR 1910.1200, and therefore is not covered by Title III of SARA.

Superfund Amendments and Reauthorization Act of 1986 Title III (Emergency Planning and Community Right-to-Know Act of 1986) Section 313

This material does not contain any chemical components with known CAS numbers that exceed the threshold (De Minimis) reporting levels established by SARA Title III, Section 313.

Pennsylvania Worker and Community Right-To-Know Act:

The following chemicals are listed because of the additional requirements of Pennsylvania law:

Components

Propylene glycol

CASRN

57-55-6

California Proposition 65 (Safe Drinking Water and Toxic Enforcement Act of 1986)

This product contains no listed substances known to the State of California to cause cancer, birth defects or other reproductive harm, at levels which would require a warning under the statute.

United States TSCA Inventory (TSCA)

All components of this product are in compliance with the inventory listing requirements of the U.S. Toxic Substances Control Act (TSCA) Chemical Substance Inventory.

:

16. OTHER INFORMATION

Hazard Rating System**NFPA**

Health	Fire	Reactivity
0	1	0

Revision

Identification Number: 101234106 / A001 / Issue Date: 04/09/2015 / Version: 7.0

Most recent revision(s) are noted by the bold, double bars in left-hand margin throughout this document.

Legend

TWA	8-hr TWA
US WEEL	USA. Workplace Environmental Exposure Levels (WEEL)

Information Source and References

This SDS is prepared by Product Regulatory Services and Hazard Communications Groups from information supplied by internal references within our company.

THE DOW CHEMICAL COMPANY urges each customer or recipient of this (M)SDS to study it carefully and consult appropriate expertise, as necessary or appropriate, to become aware of and understand the data contained in this (M)SDS and any hazards associated with the product. The information herein is provided in good faith and believed to be accurate as of the effective date shown above. However, no warranty, express or implied, is given. Regulatory requirements are subject to change and may differ between various locations. It is the buyer's/user's responsibility to ensure that his activities comply with all federal, state, provincial or local laws. The information presented here pertains only to the product as shipped. Since conditions for use of the product are not under the control of the manufacturer, it is the buyer's/user's duty to determine the conditions necessary for the safe use of this product. Due to the proliferation of sources for information such as manufacturer-specific (M)SDSs, we are not and cannot be responsible for (M)SDSs obtained from any source other than ourselves. If you have obtained an (M)SDS from another source or if you are not sure that the (M)SDS you have is current, please contact us for the most current version.

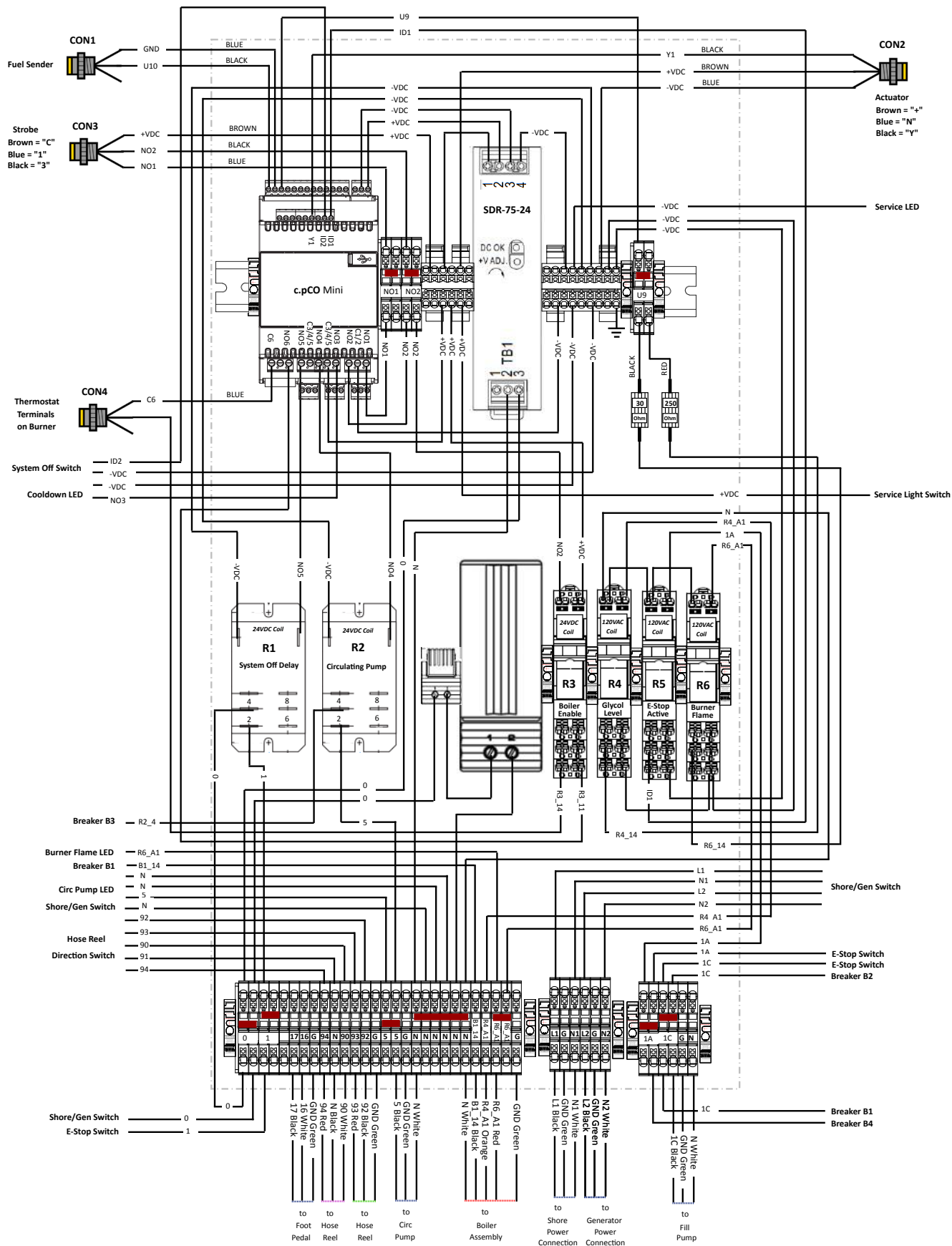

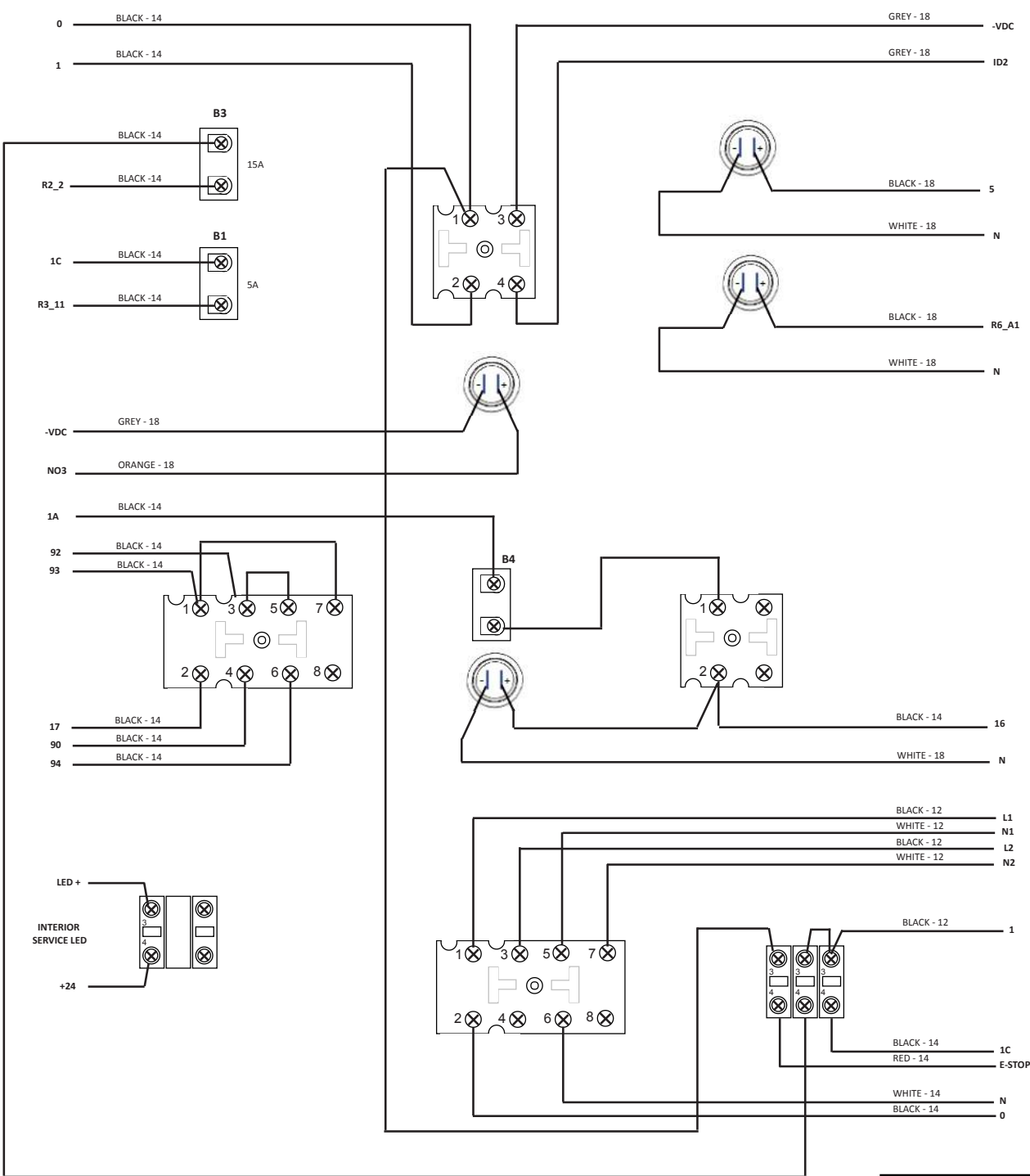
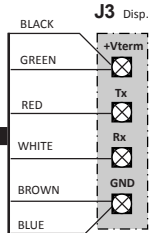
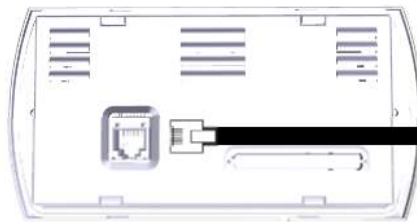
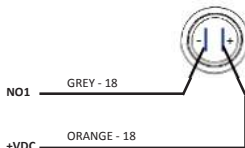

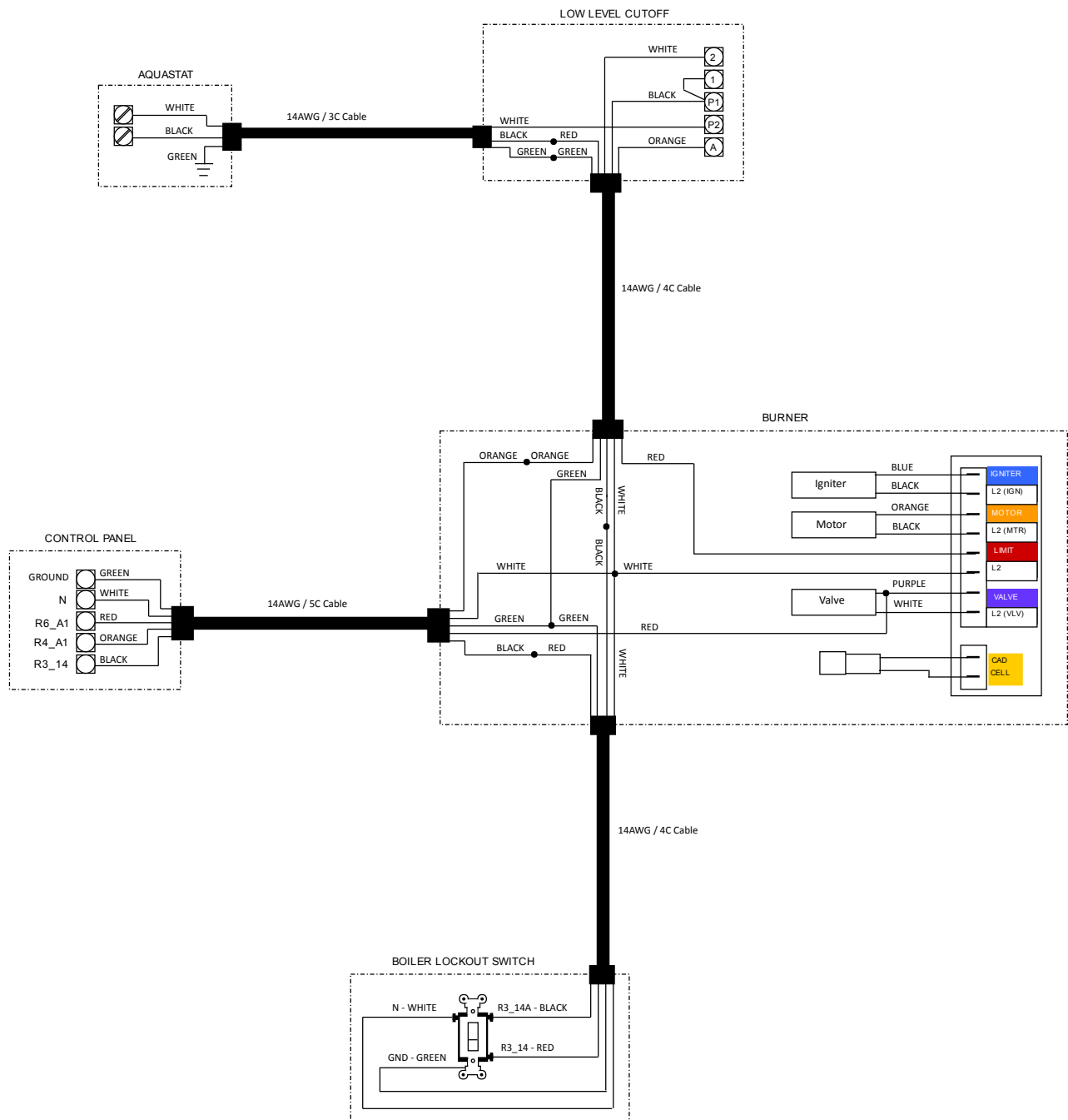

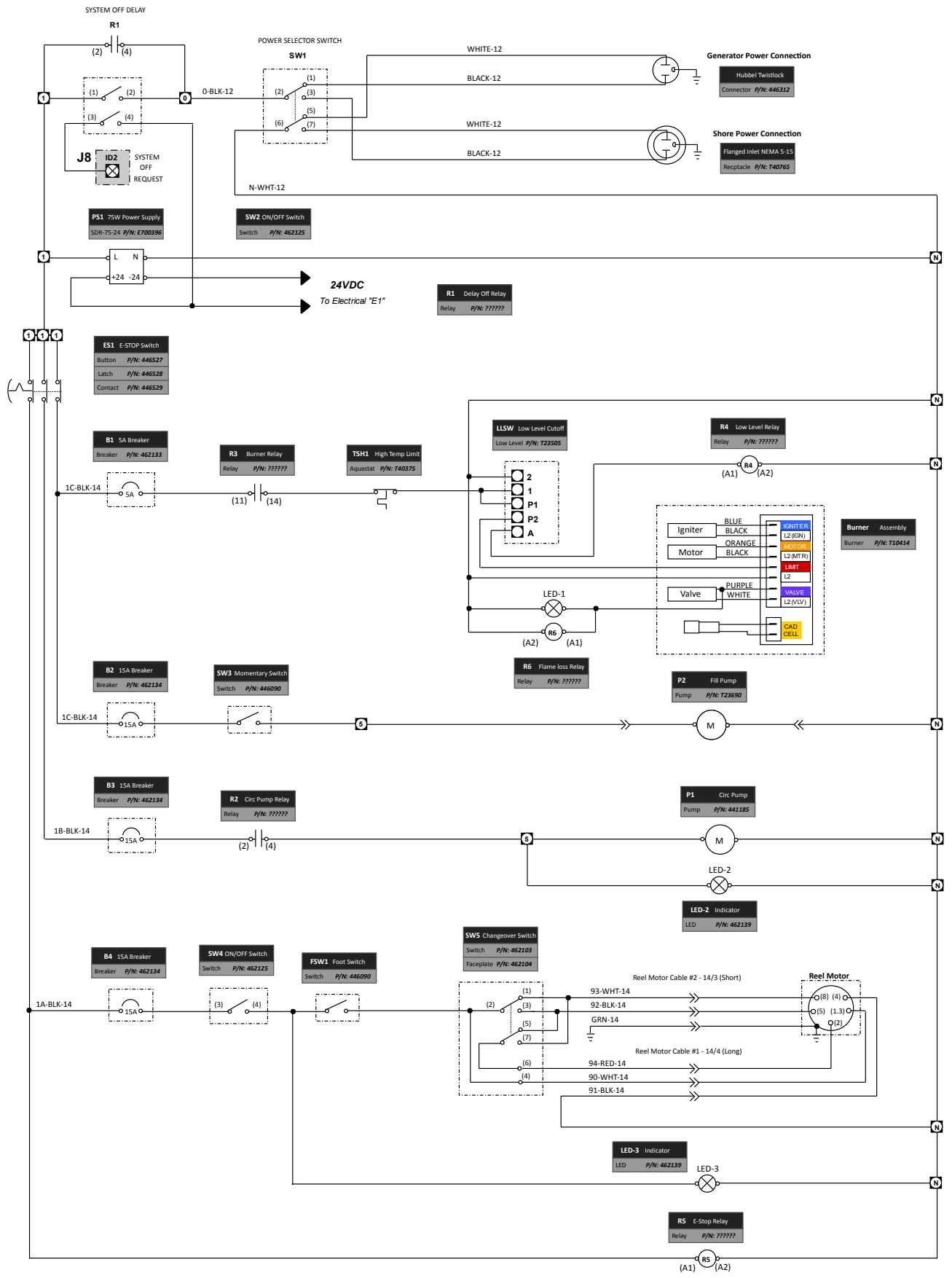

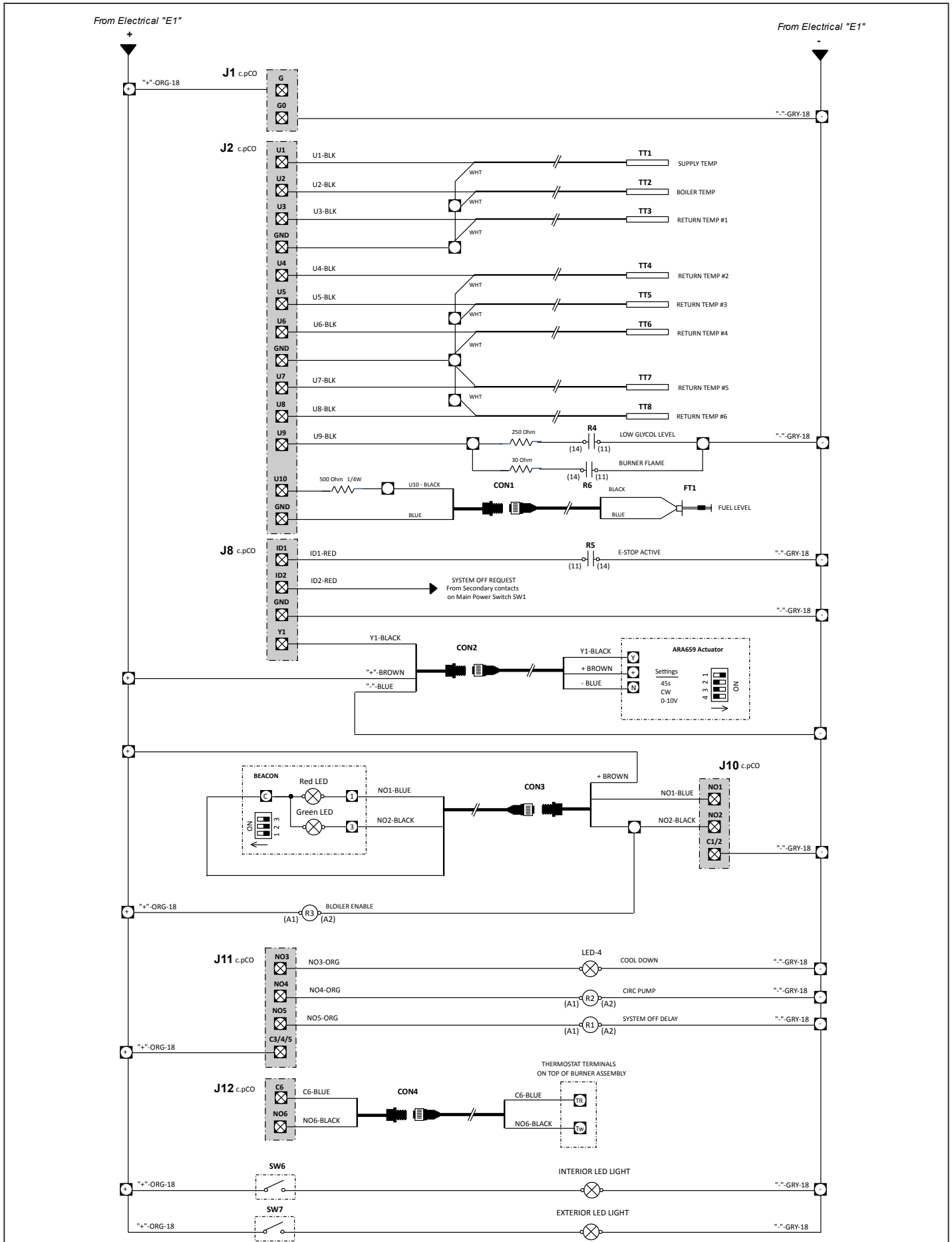

PLC Inputs and Outputs

INPUTS			
Board	Point	Description	Notes
c.pCO	U1	Glycol Supply Temperature	NTC 10K@25C
c.pCO	U2	Boiler Temperature	NTC 10K@25C
c.pCO	U3	Return Temperature Zone 1	PT1000
c.pCO	U4	Return Temperature Zone 2	PT1000
c.pCO	U5	Return Temperature Zone 3	PT1000
c.pCO	U6	Return Temperature Zone 4	PT1000
c.pCO	U7	Return Temperature Zone 5	PT1000
c.pCO	U8	Return Temperature Zone 6	PT1000
c.pCO	U9	Boiler Low Level Switch	ON/OFF (Relay Contact R4)
c.pCO	U10	Fuel Tank Level	Fuel Sender 240-30 Ohm
c.pCO	ID1	Emergency Stop	ON/OFF
c.pCO	ID2	System Off Request	ON/OFF

OUTPUTS			
Board	Point	Description	Notes
c.pCO	NO1	Strobe (Red)	PLC switches common of DC power supply (C1/2)
c.pCO	NO2	Boiler Enable, Strobe (Green)	PLC switches common of DC power supply (C1/2)
c.pCO	NO3	Cool Down LED	Blue LED, Flash during cool down
c.pCO	NO4	Circulating Pump	Relay R2
c.pCO	NO5	System Off Delay	Relay R1
c.pCO	NO6	Call For Heat/	Dry Contact Thermostat connection on Burner
c.pCO	Y1	Mixing Valve	0-10VDC (AO_MixingValve)
c.pCO	Y2	<i>Not Used</i>	

THAWZALL

Tamarack Industries



2736 Latoka Lane SW, Unit B
Alexandria, MN 56308
USA



WWW.THAWZALL.COM



support@tamarack-ind.com



1-888-757-3545



1-320-759-1583